

# ANSI X.12 Truck Manifest Implementation Guide

355 Customs Manifest Acceptance/Rejection

February 2023



U.S. Customs and  
Border Protection



MOTOR TRANSPORTATION INDUSTRY APPLICATIONS  
**CUSTOMS MANIFEST ACCEPTANCE/REJECTION**  
 Version 15 - Updated 2/14/2023

# 355 U.S. Customs Acceptance/Rejection

FUNCTIONAL GROUP ID = **AZ**

This X12 Transaction set contains the format and establishes the data contents of the Customs Acceptance/Rejection Transaction Set (355) for use within the context of an Electronic Data Interchange (EDI) environment. The transaction set can be used by U.S. Customs to report errors and discrepancies discovered in the U.S. Customs transactions sets to carriers, terminal operators, port authorities, and service centers.

**This transaction set will echo errors from the original transaction with the exception of the K1 Segments. All semi-structured text found in the K1 segments is explained in Appendix J of the CAMIR document, and in the Appendix. All semi-structured text found in the K3 segment is explained in the Transmission Acceptance and Rejection section of the CAMIR and in the Appendix.**

## Heading:

PAGE #	POS. #	SEG. ID	NAME	REQ. DES.	MAX USE	LOOP REPEAT
3	0100	ST	Transaction Set Header	M	1	
4	0200	M10	Manifest Identifying Information	M	1	
6	0300	K1	Remarks	O	10	
7	0310	VEH	Vehicle Information	O	1	
9	0315	K1	Remarks	O	10	
10	0320	M7	Seal Numbers	O	1	
11	0325	K1	Remarks	O	10	
12	0330	CII	Conveyance Insurance Information	O	1	
13	0335	K1	Remarks	O	10	
<b>LOOP ID - NM1</b>						<b>999</b>
14	0340	NM1	Individual or Organizational Name	O	1	
15	0345	K1	Remarks	O	10	
16	0350	DMG	Demographic Information	O	1	
17	0355	K1	Remarks	O	10	
N/U	0360	DMA	Additional Demographic Information	O	1	
18	0365	REF	Reference Information	O	1	
19	0370	K1	Remarks	O	10	
20	0375	N3	Party Location	O	1	
21	0380	K1	Remarks	O	10	
22	0385	N4	Geographic Location	O	1	
23	0390	K1	Remarks	O	10	
<b>LOOP ID - P4</b>						<b>20</b>
24	0400	P4	Port Information	M	1	
25	0500	K1	Remarks	O	10	
<b>LOOP ID-P4/LX</b>						<b>9999</b>
26	0600	LX	Transaction Set Line Number	M	1	
<b>LOOP ID-P4/LX/M13</b>						<b>1</b>
27	0700	M13	Manifest Amendment Details	O	1	
28	0800	K1	Remarks	O	10	
28	0800	K1	Remarks	O	10	
<b>LOOP ID-P4/LX/M11</b>						<b>1</b>
29	0900	M11	Manifest Bill of Lading Details	O	1	
31	1000	K1	Remarks	O	10	
<b>LOOP ID-P4/LX/N9</b>						<b>999</b>
32	1050	N9	Extended Reference Identification	O	1	
33	1070	K1	Remarks	O	10	
<b>LOOP ID -P4/LX/ N1</b>						<b>5</b>
34	1100	N1	Party Identification	O	1	
35	1200	K1	Remarks	O	10	
<b>Loop ID - P4/LX/N1/N2</b>						<b>1</b>
N/U	1210	N2	Additional Name Information	O	1	
N/U	1250	K1	Remarks	O	10	
<b>Loop ID - P4/LX/N1/N3</b>						<b>2</b>
36	1300	N3	Party Location	O	1	
37	1400	K1	Remarks	O	10	
<b>Loop ID - P4/LX/N1/N4</b>						<b>1</b>
38	1410	N4	Geographic Location	O	1	
39	1420	K1	Remarks	O	10	
<b>Loop ID - P4/LX/N1/N4/DTM</b>						<b>1</b>
N/U	1430	DTM	Date/Time Reference	O	1	
N/U	1435	K1	Remarks	O	10	

MOTOR TRANSPORTATION INDUSTRY APPLICATIONS  
**CUSTOMS MANIFEST ACCEPTANCE/REJECTION**

Version 15 - Updated 2/14/2023

Loop ID – P4/LX/N1/P4					1
40	1440	PER	Administrative Communications Contact	O	1
41	1450	K1	Remarks	O	10
42	1500	M12	In-bond Identifying Information	O	1
44	1510	K1	Remarks	O	10
LOOP ID –P4/LX/ M12/R4					9999
N/U	1520	R4	Port or Terminal	O	1
N/U	1530	K1	Remarks	O	10
LOOP ID – P4/LX/M12/P5					5
N/U	1550	P5	Port Function	O	1
N/U	1560	K1	Remarks	O	10
LOOP ID – P4/LX/M12/M21					1
45	1570	M21	Supplementary In-bond Information	O	1
47	1580	K1	Remarks	O	10
LOOP ID – P4/LX/M14					9999
N/U	1610	M14	General Order Status Information	O	1
N/U	1620	K1	Remarks	O	10
LOOP ID – P4/LX/M15					9999
48	1630	M15	Customs Events Advisory details	O	1
50	1640	K1	Remarks	O	10
LOOP ID – P4/LX/M20					9999
N/U	1650	M20	Permit to Transfer Request Details	O	1
N/U	1680	K1	Remarks	O	10
LOOP ID – P4/LX/VID					999
51	1700	VID	Conveyance ID	O	1
53	1750	K1	Remarks	O	10
LOOP ID P4/LX/VID/M7					999
54	1755	M7	Seal Numbers	O	1
55	1757	K1	Remarks	O	10
LOOP ID – P4/LX/VID/MBL					9999
56	1760	MBL	Bill of Lading	O	1
57	1780	K1	Remarks	O	10
LOOP ID-P4/LX/VID/M13					999
58	1800	M13	Manifest Amendment Details	O	1
59	1850	K1	Remarks	O	10
LOOP ID P4/LX/VID/ N10					999
60	2000	N10	Quantity and Description	O	1
62	2050	K1	Remarks	O	10
LOOP ID P4/LX/VID/ N10					36
63	2100	VC	Motor Vehicle Control	O	1
64	2150	K1	Remarks	O	10
LOOP ID P4/LX/VID/ MAN					999
N/U	2170	MAN	Marks and Numbers	O	1
N/U	2190	K1	Remarks	O	10
LOOP ID – P4/LX/VID/N10/H1					10
65	2200	H1	Hazardous Material	O	1
66	2300	K1	Remarks	O	10
LOOP ID – P4/LX/VID/N10/H2					99
N/U	1660	H2	Additional Hazardous Material	O	1
N/U	2300	K1	Remarks	O	10

**Detail:**

PAGE #	POS. #	SEG. ID	NAME	REQ. DES.	MAX USE	LOOP REPEAT
67	0100	K3	File Information	M	1	
69	0200	SE	Transaction Set Trailer	M	1	

**Table of Changes**

<b>Revision #</b>	<b>Date of Change</b>	<b>Section(s) Affected</b>	<b>Brief Description of Change</b>
15	February 2023	Error Appendix	Added additional error codes to match with system behavior: 377, 378, 379, 537, 538, 542, 544
14	December 2021	Error Appendix	Added in-bond validation error 255
		Error Appendix	Align with EDIFACT CUSRES errors.

MOTOR TRANSPORTATION INDUSTRY APPLICATIONS  
**CUSTOMS MANIFEST ACCEPTANCE/REJECTION**

Version 15 - Updated 2/14/2023

**Segment:** **ST** Transaction Set Header  
**Position:** 0100  
**Loop:** N/A  
**Level:** N/A  
**Usage:** Mandatory  
**Max Use:** 1  
**Purpose:** To indicate the start of a transaction set and to assign a control number  
**Syntax:** N/A  
**Semantic:**

- 1 The transaction set identifier (ST01) used by the translation routines of the interchange partners to select the appropriate transaction set definition (e.g., 810 selects the invoice transaction set)
- 2 The implementation convention reference (ST03) is used by the translation routines of the interchange partners to select the appropriate implementation convention to match the transaction set definition. When used, this implementation convention reference takes precedence over the implementation reference specified in the GS08.

**Comments:** N/A

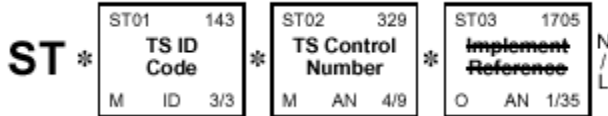

**Data Element Summary**

REF. DES. DATA ELEMENT	NAME	ATTRIBUTES
ST01 143	<b>Transaction Set Identifier Code</b> Code uniquely identifying a Transaction Set.	M ID 3/3
	CODE DEFINITION	
	355 Customs Status Information	
ST02 329	<b>Transaction Set Control Number</b> Identifying control number that must be unique within the transaction set functional group assigned by the originator for a transaction set	M AN 4/9

MOTOR TRANSPORTATION INDUSTRY APPLICATIONS  
**CUSTOMS MANIFEST ACCEPTANCE/REJECTION**

Version 15 - Updated 2/14/2023

**Segment:** M10 Manifest Identifying Information  
**Position:** 0200  
**Loop:** N/A  
**Level:** Heading  
**Usage:** Mandatory  
**Max Use:** 1  
**Purpose:** To transmit manifest identifying information  
**Syntax:** **4 P0410**  
 If either M1004 or M1010 is present, then the other is required.  
**5 R0504**  
 At least one of M1005 or M1004 is required.  
**15 P1516**  
 If either M1015 or M1016 is present, then the other is required.

**Semantic:** **4** M1004 is Lloyd's vessel code  
**7** M1007 is used for the 6-digit Numeric Manifest Sequence Number.  
**11** M1011 indicates if the transmission involves an in-bond participant. A "Y" indicates it does. A "N" indicates it does not.  
**12** M1012 is the unique identification number of the manifest described by the originator of the manifest with a maximum length of 15.  
**17** M1017 is the type of initial manifest being amended by this transmission.  
**Comments:** **A** M1003 is the code identifying the country in which the ship (vessel) is registered.  
**B** 1008 is used for Number of Bills Lading. (Maximum 5 Digits.)

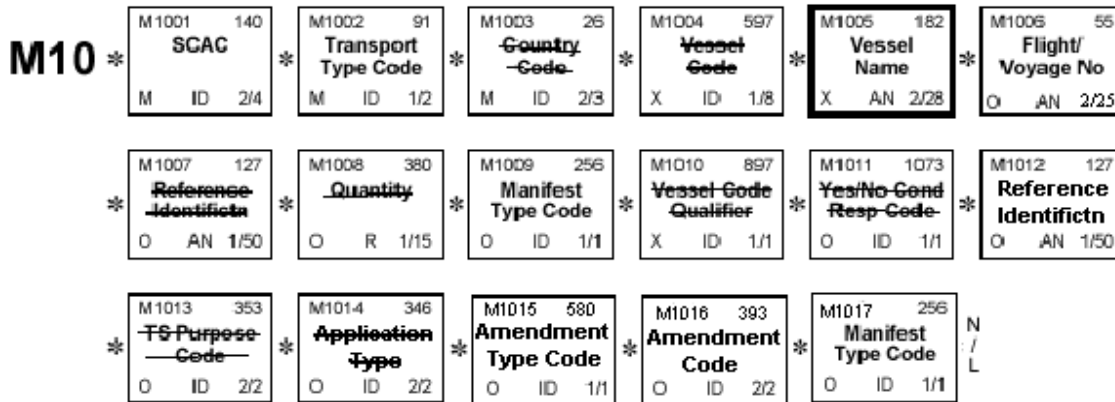

**Data Element Summary**

REF. DES.	DATA ELEMENT	NAME	ATTRIBUTES
M1001	140	Standard Carrier Alpha Code	M ID 2/4
M1002	91	Transportation Method/Type Code	M ID 1/2
M1005	182	Vessel Name	X AN 2/28
M1006	55	Flight/Voyage Number	O AN 2/10
M1009	256	Manifest Type Code	O ID 1/1
		Code identifying type of manifest transmitted between carriers and CBP.	
		<b>CODE</b> <b>DEFINITION</b>	
		H      Arrival and other notifications from carrier to CBP <b>Used for response to 353 set</b>	
		I      Supplementary in-bond information from carrier to CBP <b>Used for response to 357 set. Future use.</b>	
		P      Preliminary manifest from carrier to CBP <b>Used for response to 309 set</b>	
		W      Original manifest from carrier to CBP for imports	

MOTOR TRANSPORTATION INDUSTRY APPLICATIONS  
**CUSTOMS MANIFEST ACCEPTANCE/REJECTION**

Version 15 - Updated 2/14/2023

		<b>Used for response to 309 set</b>		
	<b>S</b>	Trip message from carrier to CBP		
		<b>Used for response to 309 set</b>		
	<b>Y</b>	Amendment to manifest from carrier to CBP		
		<b>Used for response to 309/358 set</b>		
	<b>3</b>	Delete manifest from carrier to CBP		
		<b>Used for response to 309/358 set</b>		
<b>M1012</b>	<b>127</b>	<b>Reference Identification</b>	<b>O AN</b>	<b>1/50</b>
		Reference Identification as defined for a particular Transaction Set, or as specified by the Reference Identification Qualifier.		
<b>M1015</b>	<b>580</b>	<b>Amendment Type Code</b>	<b>O ID</b>	<b>1/1</b>
		Code identifying type of manifest amendment.		
<b>M1016</b>	<b>393</b>	<b>Amendment Code</b>	<b>O ID</b>	<b>2/2</b>
		Code giving the reasons for the amendment of the manifest record.		
<b>M1017</b>	<b>256</b>	<b>Manifest Type Code</b>	<b>O AN</b>	<b>1/1</b>
		Code identifying the type of manifest transmitted between Carriers and Customs.		

MOTOR TRANSPORTATION INDUSTRY APPLICATIONS  
**CUSTOMS MANIFEST ACCEPTANCE/REJECTION**

Version 15 - Updated 2/14/2023

**Segment:** K1 Remarks  
**Position:** 0300  
**Loop:** N/A  
**Level:** Heading  
**Usage:** Optional  
**Max Use:** 10  
**Purpose:** To transmit information in a free-form format, if necessary, for comment or special instruction.  
**Syntax:** N/A  
**Semantic:** N/A  
**Comments:** N/A

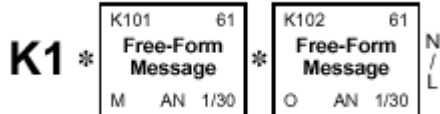

**Data Element Summary**

REF. DES.	DATA ELEMENT	NAME	ATTRIBUTES
K101	61	<b>Free Form Information</b> Free-form information.	M AN 1/30
		<b>Valid fixed format data is:</b>	
		Entity Number 'Not Applicable'	M AN 1/26
		Location Identifier Census Schedule D code representing the CBP port of first arrival	M N 4/4
K102	61	<b>Free Form Information</b> Free-form information.	O AN 1/30
		<b>A narrative explaining the error</b>	
		<b>Valid fixed format data is:</b>	
		Error Code A code defining the error taken from the error Data Dictionary	M N 3/3
		Narrative A free form definition of the error code from the Error Data Dictionary	M AN 27/27

A complete list of error codes and definitions is in the Appendix



MOTOR TRANSPORTATION INDUSTRY APPLICATIONS  
**CUSTOMS MANIFEST ACCEPTANCE/REJECTION**

Version 15 - Updated 2/14/2023

**Segment:**           **VEH**   Vehicle Information

**Position:**       0310

**Loop:**            N/A

**Level:**          Heading

**Usage:**          Optional

**Max Use:**        10

**Purpose:**         To provide descriptions that identify a specific vehicle

**Syntax:**        **4 L040507**  
                       If VEH04 is present, then at least one of VEH05 or VEH07 is required.

**5 C0504**  
                       If VEH05 is present, then VEH04 is required.

**6 C060405**  
                       If VEH06 is present, then VEH04 and VEH05 are required.

**7 C0704**  
                       If VEH07 is present, then VEH04 is required.

**10 E1026**  
                       Only one of VEH10 or VEH26 may be present

**10 C1017**  
                       If VEH10 is present, then VEH17 is required

**18 P1819**  
                       If either VEH18 or VEH19 is present, then the other is required.

**20 L200221**  
                       If VEH20 is present, then at least one of VEH02 or VEH21 is required.

**21 P2122**  
                       If either VEH21 or VEH22 is present, then the other is required.

**22 C2617**  
                       If VEH26 is present then VEH17 is required.

**Semantic:**       **4** VEH04 applies to VEH05, VEH06, and VEH07.

**5** VEH05 is the vehicle make.

**6** VEH06 is the vehicle model.

**7** VEH07 is the vehicle style.

**8** VEH08 is the length of the vehicle measured in feet.

**9** VEH09 is the vehicle reference number.

**10** VEH10 is the vehicle registration state or province.

**11** VEH11 is used to identify a territory as defined by trading partners.

**12** VEH12 is the Used Car Indicator. A 'Y' indicates the vehicle is a used vehicle; an 'N' indicates the vehicle is a new vehicle. A value of 'U' indicating unknown cannot be used.

**13** VEH13 is the original cost of the vehicle when it was new (i.e. OCN – original cost new).

**14** VEH14 is the Vehicle Altered Indicator. A 'Y' indicates the vehicle was altered; an 'N' indicates the vehicle was not altered. A value of 'U' indicating unknown cannot be used.

**15** VEH15 is the value of the alterations for a vehicle.

**17** VEH17 is the Country of the State in VEH10 or the country subdivision in VEH26.

**18** VEH18 is the Name of the Vehicle Owner.

**19** VEH19 is the Residence Country of the Vehicle Owner in VEH18

**21** VEH21 is the ACE (Automated Commercial Environment) ID assigned by US Customs and Border Protection.

**24** VEH24 is the transponder number of the vehicle.

**25** VEH25 is the Department of Transportation (DOT) number of the vehicle.

**Comments:**      N/A

MOTOR TRANSPORTATION INDUSTRY APPLICATIONS  
 CUSTOMS MANIFEST ACCEPTANCE/REJECTION

Version 15 - Updated 2/14/2023

<b>VEH</b> *	VEH01 554 Assigned Number O ND 1/6	VEH02 339 Vehicle ID Number K AN 1/30	VEH03 1085 Year O ND 4/4	VEH04 559 Agency Qual Code X/Z ID 2/2	VEH05 127 Reference Identifier X/Z AN	VEH06 127 Reference Identifier O/Z AN 1/80
*	VEH07 127 Reference Identifier X/Z AN 1/80	VEH08 82 Length O/Z R 1/8	VEH09 127 Reference Identifier O/Z AN 1/80	VEH10 155 State or Prov Code X/Z ID 2/2	VEH11 310 Location Identifier O/Z AN 1/30	VEH12 1073 Year/No Code Resp Code O/Z ID 1/1
*	VEH13 510 Amount O/Z N2 1/15	VEH14 1073 Year/No Code Resp Code O/Z ID 1/1	VEH15 510 Amount O/Z N2 1/15	VEH16 306 Action Code D ID 1/2	VEH17 26 Country Code X/Z ID 2/3	VEH18 93 Name X/Z AN 1/60
*	VEH19 26 Country Code X/Z ID 2/3	VEH20 40 Equipment Desc Code O ID 2/2	VEH21 127 Reference Identifier K AN	VEH22 128 ID Code Qualifier K AN 2/3	VEH23 322 Load/Empty Status Code O ID 1/1	VEH24 127 Reference Identifier O/Z AN 1/80
*	VEH25 127 Reference Identifier O/Z AN 1/80	VEH26 1715 Country Subdivision X ID 1/3				

Data Element Summary

REF. DES.	DATA ELEMENT	NAME	ATTRIBUTES
VEH02	539	<b>Vehicle Identification Number</b> Unique identification number stamped on the vehicle by the manufacturer.	X AN 1/30
VEH09	127	<b>Reference Identification</b> Reference identification as defined for a particular Transaction Set, or as specified by the Reference Identification Qualifier.	O/Z AN 1/80
VEH17	26	<b>Country Code</b> Code identifying the country. The 2 alpha ISO country code of the state/province in VEH10.	X/Z ID 2/3
VEH20	40	<b>Equipment Description Code</b> Code identifying the type of conveyance	O ID 2/2
VEH21	127	<b>Reference Identification</b> Reference identification as defined for a particular Transaction Set, or as specified by the Reference Identification Qualifier.	X AN 1/80
VEH22	128	<b>ID Code Qualifier</b> Code designating the system/method of code structure used for identification.	X ID 2/3
VEH23	322	<b>Load/empty Status Code</b> Code qualifying VEH20	O ID 1/1
VEH24	127	<b>Reference Identification</b> Reference identification as defined for a particular Transaction Set, or as specified by the Reference Identification Qualifier.	O/Z AN 1/80
VEH25	127	<b>Reference Identification</b> Reference identification as defined for a particular Transaction Set, or as specified by the Reference Identification Qualifier. This is the DOT Number.	O/Z AN 1/80
VEH26	1715	<b>Country Subdivision</b> Code identifying the country subdivision	X ID 1/3

MOTOR TRANSPORTATION INDUSTRY APPLICATIONS  
**CUSTOMS MANIFEST ACCEPTANCE/REJECTION**

Version 15 - Updated 2/14/2023

**Segment:** K1 Remarks  
**Position:** 0315  
**Loop:** N/A  
**Level:** Heading  
**Usage:** Optional  
**Max Use:** 10  
**Purpose:** To transmit information in a free-form format, if necessary, for comment or special instruction.  
**Syntax:** N/A  
**Semantic:** N/A  
**Comments:** N/A

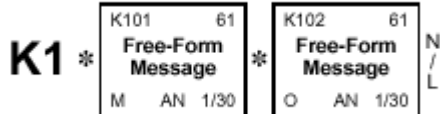

**Data Element Summary**

REF. DES.	DATA ELEMENT	NAME	ATTRIBUTES
K101	61	<b>Free Form Information</b> Free-form information.	M AN 1/30
		<b>Valid fixed format data is:</b>	
		Entity Number 'Not Applicable'	M AN 1/26
		Location Identifier Census Schedule D code representing the CBP port of first arrival	M N 4/4
K102	61	<b>Free Form Information</b> Free-form information.	O AN 1/30
		<b>A narrative explaining the error</b>	
		<b>Valid fixed format data is:</b>	
		Error Code A code defining the error taken from the error Data Dictionary	M N 3/3
		Narrative A free form definition of the error code from the Error Data Dictionary	M AN 27/27

A complete list of error codes and definitions is in the Appendix

MOTOR TRANSPORTATION INDUSTRY APPLICATIONS  
**CUSTOMS MANIFEST ACCEPTANCE/REJECTION**

Version 15 - Updated 2/14/2023

**Segment:** M7 Seal Numbers  
**Position:** 0320  
**Loop:** N/A  
**Level:** Heading  
**Usage:** Optional  
**Max Use:** 1  
**Purpose:** To record seal numbers used and the organization that applied the seals.  
**Syntax:** N/A  
**Semantic:** N/A  
**Comments:** 5 M705 indicates the name of the organization who applied the seal(s)

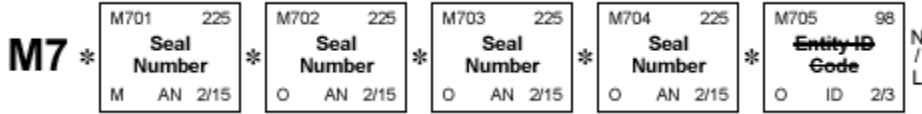

**Data Element Summary**

REF. DES.	DATA ELEMENT	NAME	ATTRIBUTES
M701	225	<b>Seal Number</b> Unique number on seal used to close a shipment.	M AN 2/15
M702	225	<b>Seal Number</b> Unique number on seal used to close a shipment.	O AN 2/15
M703	225	<b>Seal Number</b> Unique number on seal used to close a shipment.	O AN 2/15
M704	225	<b>Seal Number</b> Unique number on seal used to close a shipment.	O AN 2/15

MOTOR TRANSPORTATION INDUSTRY APPLICATIONS  
**CUSTOMS MANIFEST ACCEPTANCE/REJECTION**

Version 15 - Updated 2/14/2023

**Segment:** K1 Remarks  
**Position:** 0325  
**Loop:** N/A  
**Level:** Heading  
**Usage:** Optional  
**Max Use:** 10  
**Purpose:** To transmit information in a free-form format, if necessary, for comment or special instruction.  
**Syntax:** N/A  
**Semantic:** N/A  
**Comments:** N/A

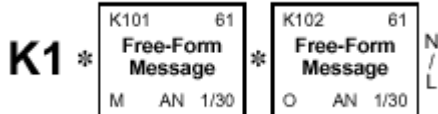

**Data Element Summary**

REF. DES.	DATA ELEMENT	NAME	ATTRIBUTES
K101	61	<b>Free Form Information</b> Free-form information.	M AN 1/30
		<b>Valid fixed format data is:</b>	
		Entity Number 'Not Applicable'	M AN 1/26
		Location Identifier Census Schedule D code representing the CBP port of first arrival	M N 4/4
K102	61	<b>Free Form Information</b> Free-form information.	O AN 1/30
		<b>A narrative explaining the error</b>	
		<b>Valid fixed format data is:</b>	
		Error Code A code defining the error taken from the error Data Dictionary	M N 3/3
		Narrative A free form definition of the error code from the Error Data Dictionary	M AN 27/27

A complete list of error codes and definitions is in the Appendix

MOTOR TRANSPORTATION INDUSTRY APPLICATIONS  
**CUSTOMS MANIFEST ACCEPTANCE/REJECTION**

Version 15 - Updated 2/14/2023

**Segment:** CII Conveyance Insurance Information  
**Position:** 0330  
**Loop:** Heading  
**Level:** N/A  
**Usage:** Optional  
**Max Use:** 1  
**Purpose:** Conveyance Insurance Information  
**Syntax:** N/A  
**Semantic:** 1 CII01 is the Name of the Insurance Company  
 2 CII02 is the Policy Number of the Insurance  
 3 CII03 is the Year policy in CII02 was Issued  
 5 CII05 is the Amount of the Insurance on policy in CII02

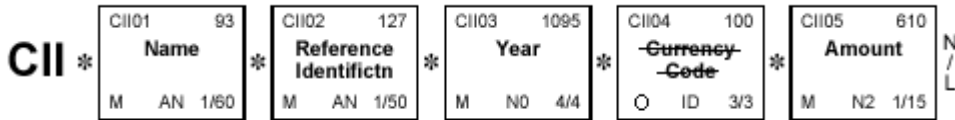

**Data Element Summary**

REF. DES.	DATA ELEMENT	NAME	ATTRIBUTES		
CII01	93	<b>Name</b> Free-form name.	M	AN	1/60
CII02	127	<b>Reference Identification</b> Reference identification as defined for a particular Transaction Set, or as specified by the Reference Identification Qualifier.	M	AN	1/50
CII03	1095	<b>Year</b> Four position designation of the year expressed as CCYY.	M	N0	4/4
CII05	610	<b>Amount</b> Monetary amount. Amount of insurance covered in CII02.	M	N2	1/15

MOTOR TRANSPORTATION INDUSTRY APPLICATIONS  
**CUSTOMS MANIFEST ACCEPTANCE/REJECTION**

Version 15 - Updated 2/14/2023

**Segment:** K1 Remarks  
**Position:** 0315  
**Loop:** N/A  
**Level:** Heading  
**Usage:** Optional  
**Max Use:** 10  
**Purpose:** To transmit information in a free-form format, if necessary, for comment or special instruction.  
**Syntax:** N/A  
**Semantic:** N/A  
**Comments:** N/A

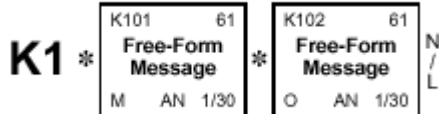

**Data Element Summary**

REF. DES.	DATA ELEMENT	NAME	ATTRIBUTES
K101	61	<b>Free Form Information</b> Free-form information.	M AN 1/30
		<b>Valid fixed format data is:</b>	
		Entity Number 'Not Applicable'	M AN 1/26
		Location Identifier Census Schedule D code representing the CBP port of first arrival	M N 4/4
K102	61	<b>Free Form Information</b> Free-form information.	O AN 1/30
		<b>A narrative explaining the error</b>	
		<b>Valid fixed format data is:</b>	
		Error Code A code defining the error taken from the error Data Dictionary	M N 3/3
		Narrative A free form definition of the error code from the Error Data Dictionary	M AN 27/27

A complete list of error codes and definitions is in the Appendix

MOTOR TRANSPORTATION INDUSTRY APPLICATIONS  
**CUSTOMS MANIFEST ACCEPTANCE/REJECTION**

Version 15 - Updated 2/14/2023

**Segment:** NM1 Individual or Organizational Name  
**Position:** 0340  
**Loop:** NM1  
**Level:** N/A  
**Usage:** Optional  
**Max Use:** 1  
**Purpose:** To supply the full name of an individual or organizational entity  
**Syntax:** **1 P0809**  
 If either NM108 or NM109 is present, then the other is required.  
**2 C1110**  
 If NM111 is present, then NM110 is required.  
**3 C1203**  
 If NM112 is present, then NM103 is required.  
**Semantic:** 2 NM102 qualifies NM103.  
**Comments:** **A** NM110 and NM111 further define the type of entity in NM101.  
**B** NM112 can identify a second surname.

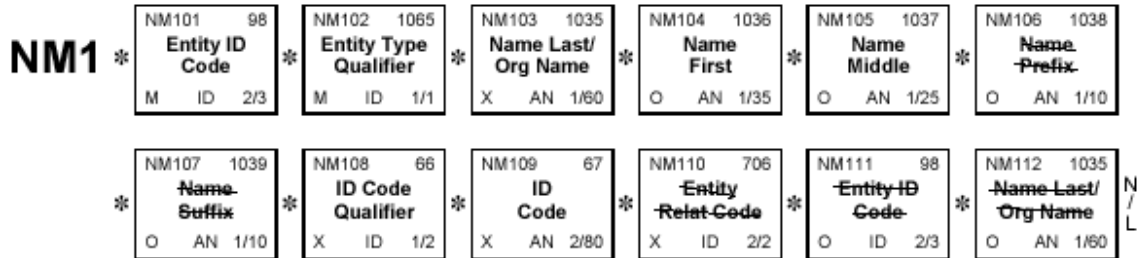

**Data Element Summary**

REF. DES.	DATA ELEMENT	NAME	ATTRIBUTES
NM101	98	<b>Entity Identifier Code</b> Code identifying an organizational entity, a physical location, or an individual	M ID 2/3
NM102	1065	<b>Entity Type Qualifier</b> Code qualifying the type of entity.	M ID 1/1
NM103	1035	<b>Name Last or Organizational Name</b> Individual last name or organizational name.	X AN 1/60
NM104	1036	<b>Name First</b> Individual first name.	O AN 1/35
NM105	1037	<b>Name Middle</b> Individual middle name or initial.	O AN 1/25
NM108	66	<b>Identification Code Qualifier</b> Code designating the system/method of code structure used for Identification	X ID 1/2
NM109	67	<b>Identification Code</b> Code identifying a party or other code.	X AN 2/80



MOTOR TRANSPORTATION INDUSTRY APPLICATIONS  
**CUSTOMS MANIFEST ACCEPTANCE/REJECTION**

Version 15 - Updated 2/14/2023

**Segment:** K1 Remarks  
**Position:** 0345  
**Loop:** NM1  
**Level:** Heading  
**Usage:** Optional  
**Max Use:** 10  
**Purpose:** To transmit information in a free-form format, if necessary, for comment or special instruction.  
**Syntax:** N/A  
**Semantic:** N/A  
**Comments:** N/A

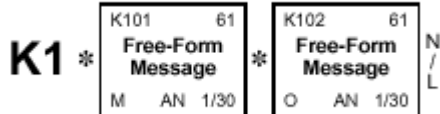

**Data Element Summary**

REF. DES.	DATA ELEMENT	NAME	ATTRIBUTES
K101	61	<b>Free Form Information</b> Free-form information.	M AN 1/30
		<b>Valid fixed format data is:</b>	
		Entity Number 'Not Applicable'	M AN 1/26
		Location Identifier Census Schedule D code representing the CBP port of first arrival	M N 4/4
K102	61	<b>Free Form Information</b> Free-form information.	O AN 1/30
		<b>A narrative explaining the error</b>	
		<b>Valid fixed format data is:</b>	
		Error Code A code defining the error taken from the error Data Dictionary	M N 3/3
		Narrative A free form definition of the error code from the Error Data Dictionary	M AN 27/27

A complete list of error codes and definitions is in the Appendix

MOTOR TRANSPORTATION INDUSTRY APPLICATIONS  
**CUSTOMS MANIFEST ACCEPTANCE/REJECTION**

Version 15 - Updated 2/14/2023

**Segment:** **DMG** Demographic Information

**Position:** 0350

**Loop:** NM1

**Level:** Heading

**Usage:** Optional

**Max Use:** 1

**Purpose:** To supply demographic information

**Syntax:** **1 P0102**

If either DMG01 or DMG02 is present, then the other is required.

**2 P1011**

If either DMG10 or DMG11 is present, then the other is required.

**3 C1105**

If DMG11 is present, then DMG05 is required.

**Semantic:**

**2** DMG02 is the date of birth.

**7** DMG07 is the country of citizenship.

**9** DMG09 is the age in years

**11** DMG11 is used to specify how the information in DMG05, including repeats of C056 was collected.

**Comments:** N/A

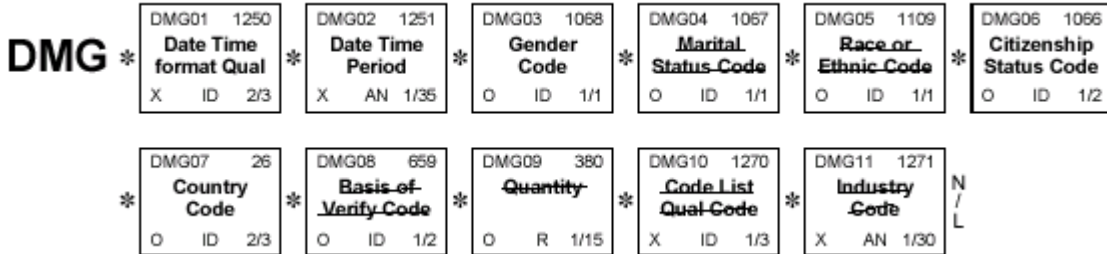

**Data Element Summary**

REF. DES.	DATA ELEMENT	NAME	ATTRIBUTES
DMG01	1250	<b>Date Time Period Format Qualifier</b> Code indicating the date format, time format, or date and time format.	X ID 2/3
DMG02	1251	<b>Date Time Period</b> Expression of a date, a time, or range of dates, times or dates and times.	X AN 1/35
DMG03	1068	<b>Gender Code</b> Code indicating the sex of the individual.	O ID 1/1
DMG06	1066	<b>Citizenship Status Code</b> Code indicating the citizenship status.	O ID 1/2
DMG07	26	<b>Country Code</b> Code identifying the country.	O ID 2/3

MOTOR TRANSPORTATION INDUSTRY APPLICATIONS  
**CUSTOMS MANIFEST ACCEPTANCE/REJECTION**

Version 15 - Updated 2/14/2023

**Segment:** K1 Remarks  
**Position:** 0355  
**Loop:** NM1  
**Level:** Heading  
**Usage:** Optional  
**Max Use:** 10  
**Purpose:** To transmit information in a free-form format, if necessary, for comment or special instruction.  
**Syntax:** N/A  
**Semantic:** N/A  
**Comments:** N/A

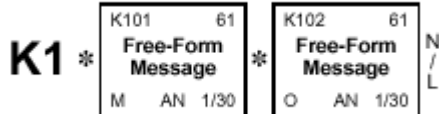

**Data Element Summary**

REF. DES.	DATA ELEMENT	NAME	ATTRIBUTES
K101	61	<b>Free Form Information</b> Free-form information.	M AN 1/30
		<b>Valid fixed format data is:</b>	
		Entity Number 'Not Applicable'	M AN 1/26
		Location Identifier Census Schedule D code representing the CBP port of first arrival	M N 4/4
K102	61	<b>Free Form Information</b> Free-form information.	O AN 1/30
		<b>A narrative explaining the error</b>	
		<b>Valid fixed format data is:</b>	
		Error Code A code defining the error taken from the error Data Dictionary	M N 3/3
		Narrative A free form definition of the error code from the Error Data Dictionary	M AN 27/27

A complete list of error codes and definitions is in the Appendix

MOTOR TRANSPORTATION INDUSTRY APPLICATIONS  
**CUSTOMS MANIFEST ACCEPTANCE/REJECTION**  
 Version 15 - Updated 2/14/2023

**Segment:** REF Reference Information

**Position:** 0365  
**Loop:** NM1  
**Level:** Heading  
**Usage:** Optional  
**Max Use:** 10  
**Purpose:** To specify identifying information  
**Syntax:** **1 R0203**

At least one of REF02 or REF03 is required.  
 2 If either C04003 or C04004 is present, then the other is required.  
 3 If either C04005 or C04006 is present, then the other is required.

**Semantic:** 4 REF04 contains data relating to the value cited in REF02  
**Comments:** N/A

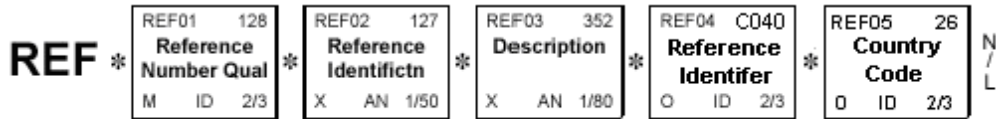

**Data Element Summary**

REF. DES.	DATA ELEMENT	NAME	ATTRIBUTES
REF01	128	<b>Reference Number Qualifier</b> Code qualifying the Reference Identification.	M ID 2/3
REF02	127	<b>Reference Identification</b> Reference information as defined for a particular Transaction Set, or as specified by the Reference Identification Qualifier.	X AN 1/50
REF03	352	<b>Description</b> A free-form description to clarify the related data elements and their content.	X AN 1/80
REF04	C040	<b>Reference Identifier</b> To identify one or more reference numbers or identification numbers as specified by the reference qualifier.	O ID 1/3
REF05	26	<b>Country Code</b> Code identifying the country	O ID 1/3

MOTOR TRANSPORTATION INDUSTRY APPLICATIONS  
**CUSTOMS MANIFEST ACCEPTANCE/REJECTION**

Version 15 - Updated 2/14/2023

**Segment:** K1 Remarks  
**Position:** 0370  
**Loop:** NM1  
**Level:** Heading  
**Usage:** Optional  
**Max Use:** 10  
**Purpose:** To transmit information in a free-form format, if necessary, for comment or special instruction.  
**Syntax:** N/A  
**Semantic:** N/A  
**Comments:** N/A

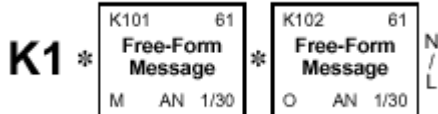

**Data Element Summary**

REF. DES.	DATA ELEMENT	NAME	ATTRIBUTES
K101	61	<b>Free Form Information</b> Free-form information.	M AN 1/30
		<b>Valid fixed format data is:</b>	
		Entity Number 'Not Applicable'	M AN 1/26
		Location Identifier Census Schedule D code representing the CBP port of first arrival	M N 4/4
K102	61	<b>Free Form Information</b> Free-form information.	O AN 1/30
		<b>A narrative explaining the error</b>	
		<b>Valid fixed format data is:</b>	
		Error Code A code defining the error taken from the error Data Dictionary	M N 3/3
		Narrative A free form definition of the error code from the Error Data Dictionary	M AN 27/27

A complete list of error codes and definitions is in the Appendix

MOTOR TRANSPORTATION INDUSTRY APPLICATIONS  
**CUSTOMS MANIFEST ACCEPTANCE/REJECTION**

Version 15 - Updated 2/14/2023

**Segment:** N3 Party Location  
**Position:** 0375  
**Loop:** NM1  
**Level:** Heading  
**Usage:** Optional  
**Max Use:** 2  
**Purpose:** To specify the location of the named party  
**Syntax:** N/A  
**Semantic:** N/A  
**Comments:** N/A

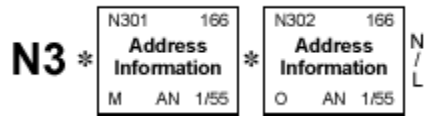

**Data Element Summary**

REF. DES.	DATA ELEMENT	NAME	ATTRIBUTES	
N301	166	Address Information	M	AN 1/55
N30 2	166	Address Information	O	AN 1/55

MOTOR TRANSPORTATION INDUSTRY APPLICATIONS  
**CUSTOMS MANIFEST ACCEPTANCE/REJECTION**

Version 15 - Updated 2/14/2023

**Segment:** K1 Remarks  
**Position:** 0380  
**Loop:** NM1  
**Level:** Heading  
**Usage:** Optional  
**Max Use:** 10  
**Purpose:** To transmit information in a free-form format, if necessary, for comment or special instruction.  
**Syntax:** N/A  
**Semantic:** N/A  
**Comments:** N/A

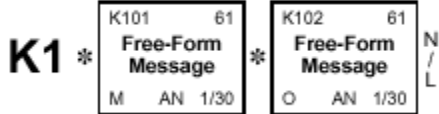

**Data Element Summary**

REF. DES.	DATA ELEMENT	NAME	ATTRIBUTES
K101	61	<b>Free Form Information</b> Free-form information.	M AN 1/30
		<b>Valid fixed format data is:</b>	
		Entity Number 'Not Applicable'	M AN 1/26
		Location Identifier Census Schedule D code representing the CBP port of first arrival	M N 4/4
K102	61	<b>Free Form Information</b> Free-form information.	O AN 1/30
		<b>A narrative explaining the error</b>	
		<b>Valid fixed format data is:</b>	
		Error Code A code defining the error taken from the error Data Dictionary	M N 3/3
		Narrative A free form definition of the error code from the Error Data Dictionary	M AN 27/27

A complete list of error codes and definitions is in the Appendix

MOTOR TRANSPORTATION INDUSTRY APPLICATIONS  
**CUSTOMS MANIFEST ACCEPTANCE/REJECTION**

Version 15 - Updated 2/14/2023

**Segment:** N4 Geographic Location  
**Position:** 0385  
**Loop:** NM1  
**Level:** Heading  
**Usage:** Optional  
**Max Use:** 1  
**Purpose:** To specify the geographic place of the named party  
**Syntax:** 1 **E0207**

Only one of N402 or N407 may be present.

2 **C0605**

If N406 is present, then N405 is required.

3 **C0704**

If N407 is present, then N404 is required.

**Semantic:** N/A

**Comments:** **A** A combination of either N401 through N404 (or N405 and N406) may be adequate to specify a location.

**B** N402 is required only if city name (N401) is in the U.S. or Canada

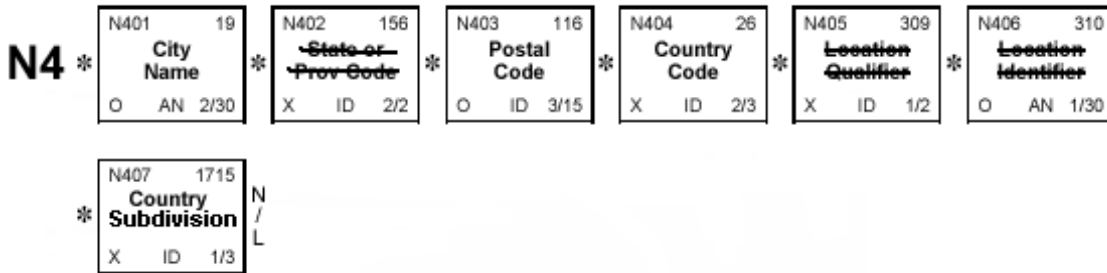

**Data Element Summary**

REF. DES.	DATA ELEMENT	NAME	ATTRIBUTES
N401	19	<b>City Name</b> Free-form text for city name.	O AN 2/30
N403	116	<b>Postal Code</b> Code defining international postal zone code excluding punctuation and blanks	O ID 3/15
N404	26	<b>Country Code</b> Code identifying the country	X ID 2/3
N407	1715	<b>Country Subdivision</b> Code identifying the country subdivision	X ID 1/3



MOTOR TRANSPORTATION INDUSTRY APPLICATIONS  
**CUSTOMS MANIFEST ACCEPTANCE/REJECTION**

Version 15 - Updated 2/14/2023

**Segment:** K1 Remarks  
**Position:** 0390  
**Loop:** N/A  
**Level:** Heading  
**Usage:** Optional  
**Max Use:** 10  
**Purpose:** To transmit information in a free-form format, if necessary, for comment or special instruction.  
**Syntax:** N/A  
**Semantic:** N/A  
**Comments:** N/A

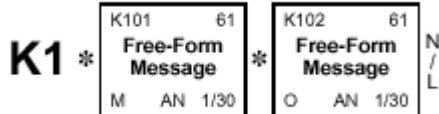

**Data Element Summary**

REF. DES.	DATA ELEMENT	NAME	ATTRIBUTES
K101	61	<b>Free Form Information</b> Free-form information.	M AN 1/30
		<b>Valid fixed format data is:</b>	
		Entity Number 'Not Applicable'	M AN 1/26
		Location Identifier Census Schedule D code representing the CBP port of first arrival	M N 4/4
K102	61	<b>Free Form Information</b> Free-form information.	O AN 1/30
		<b>A narrative explaining the error</b>	
		<b>Valid fixed format data is:</b>	
		Error Code A code defining the error taken from the error Data Dictionary	M N 3/3
		Narrative A free form definition of the error code from the Error Data Dictionary	M AN 27/27

A complete list of error codes and definitions is in the Appendix

MOTOR TRANSPORTATION INDUSTRY APPLICATIONS  
**CUSTOMS MANIFEST ACCEPTANCE/REJECTION**

Version 15 - Updated 2/14/2023

**Segment:** P4 Port Information

**Position:** 0400

**Loop:** P4

**Level:** Heading

**Usage:** Mandatory

**Max Use:** 1

**Purpose:** To transmit identifying information for a port

**Syntax:** N/A

- Semantic:**
- 1 P401 is used for CBP port code (Census Schedule D).
  - 2 P402 is the estimated date of arrival.
  - 3 P403 is used for number of bills of lading.
  - 4 P404 is the Facilities Information and Resources Management System (FIRMS) Code
  - 5 P405 is the Estimated Time of Arrival for P402
  - 6 P406 is the date conveyance departed prior port.
  - 7 P407 is the time conveyance departed prior port.

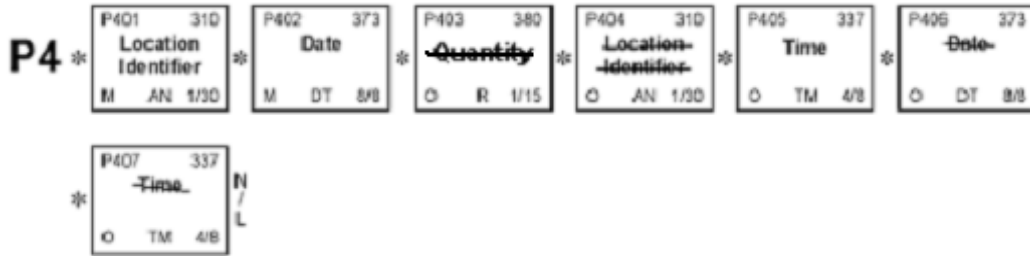

**Data Element Summary**

REF. DES.	DATA ELEMENT	NAME	ATTRIBUTES
P401	310	<b>Location Identifier</b> Code which identifies a specific location.	M AN 1/30
P402	373	<b>Date</b> Date expressed as CCYYMMDD where CC represents the first two digits of the calendar year.	M DT 8/8
P405	337	<b>Time</b> Time expressed in 24-hour clock time as follows: HHMM, or HHMMSS, or HHMMSSDD, where H = hours (00-25), M=minutes (00-59), S = integer seconds, and DD= decimal seconds, decimal seconds are expressed as follows: D = tenths (0-9) and DD = hundredths (00-99).	O TM 4/8

MOTOR TRANSPORTATION INDUSTRY APPLICATIONS  
**CUSTOMS MANIFEST ACCEPTANCE/REJECTION**

Version 15 - Updated 2/14/2023

**Segment:** K1 Remarks  
**Position:** 0500  
**Loop:** N/A  
**Level:** Heading  
**Usage:** Optional  
**Max Use:** 10  
**Purpose:** To transmit information in a free-form format, if necessary, for comment or special instruction.  
**Syntax:** N/A  
**Semantic:** N/A  
**Comments:** N/A

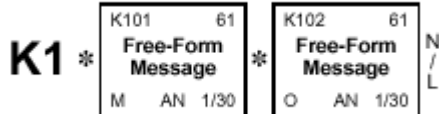

**Data Element Summary**

REF. DES.	DATA ELEMENT	NAME	ATTRIBUTES
K101	61	<b>Free Form Information</b> Free-form information.	M AN 1/30
		<b>Valid fixed format data is:</b>	
		Entity Number 'Not Applicable'	M AN 1/26
		Location Identifier Census Schedule D code representing the CBP port of first arrival	M N 4/4
K102	61	<b>Free Form Information</b> Free-form information.	O AN 1/30
		<b>A narrative explaining the error</b>	
		<b>Valid fixed format data is:</b>	
		Error Code A code defining the error taken from the error Data Dictionary	M N 3/3
		Narrative A free form definition of the error code from the Error Data Dictionary	M AN 27/27

A complete list of error codes and definitions is in the Appendix

MOTOR TRANSPORTATION INDUSTRY APPLICATIONS  
CUSTOMS MANIFEST ACCEPTANCE/REJECTION

Version 15 - Updated 2/14/2023

**Segment:** LX Transaction Set Line Number

**Position:** 0600

**Loop:** LX

**Level:** Heading

**Usage:** Optional

**Max Use:** 1

**Purpose:** To reference a line number in a transaction set.

**Syntax:** N/A

**Semantic:** N/A

**Comments:** N/A

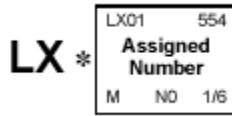

**Data Element Summary**

REF. DES. DATA ELEMENT  
LX01 554

NAME  
**Assigned Number**  
Number assigned for differentiation within a transaction set.

ATTRIBUTES  
M NO 1/6

MOTOR TRANSPORTATION INDUSTRY APPLICATIONS  
**CUSTOMS MANIFEST ACCEPTANCE/REJECTION**

Version 15 - Updated 2/14/2023

**Segment:** M13 Manifest Amendment Details

**Position:** 0700  
**Loop:** M13  
**Level:** Heading  
**Usage:** Optional  
**Max Use:** 1  
**Purpose:** To correct a manifest record prior to vessel arrival or to amend a manifest record after conveyance arrival.

**Syntax:** 1 P0810  
 If either M1308 or M1310 is present, then the other is required.  
 2 P1112  
 If either M1311 or M1312 is present, then the other is required.

**Semantic:** 1 M1301 is the Bill of Lading Issuer.  
 2 M1302 is used for discharge port (4-digit numeric census schedule D).  
 3 M1305 is new manifest quantity and is used if M1303 = "R"  
 8 M1308 is used to report individual portions of a consolidated shipment.  
 9 M1309 is the conveyance operator's Standard Carrier Alpha Code  
 10 M1310 is the issuer code for the consolidated shipment.

**Comments:** N/A

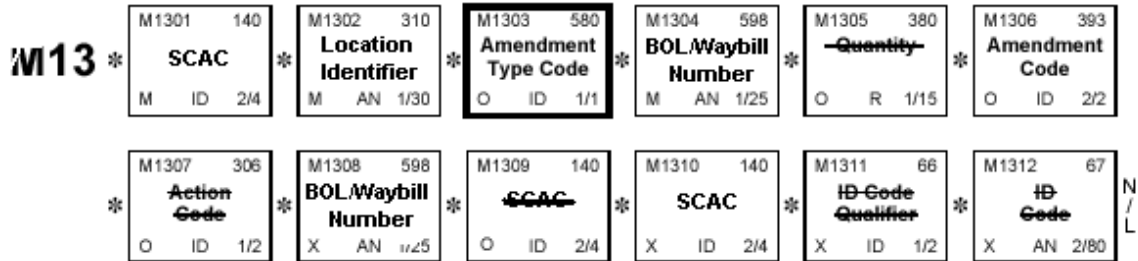

**Data Element Summary**

REF. DES.	DATA ELEMENT	NAME	ATTRIBUTES
M1301	140	<b>Standard Carrier Alpha Code</b> Standard Carrier Alpha Code	M ID 2/4
M1302	310	<b>Location Identifier</b> Code which identifies a specific location.	M AN 1/30
M1303	580	<b>Amendment Type Code</b> Code identifying type of manifest amendment.	O ID 1/1
M1304	598	<b>Bill of Lading/Waybill Number</b> Identification number assigned to the shipment by the carrier or consolidator.	M AN 1/25
M1306	393	<b>Amendment Code</b> Code giving the reasons for the amendment of the manifest record.	O ID 2/2
M1308	598	<b>Bill of lading/Waybill Number</b> Identification number assigned to the shipment by the carrier or consolidator.	X AN 1/25
M1310	140	<b>Standard Carrier Alpha Code</b> Standard Carrier Alpha Code	X ID 2/4

MOTOR TRANSPORTATION INDUSTRY APPLICATIONS  
**CUSTOMS MANIFEST ACCEPTANCE/REJECTION**

Version 15 - Updated 2/14/2023

**Segment:** K1 Remarks  
**Position:** 0800  
**Loop:** M13  
**Level:** Heading  
**Usage:** Optional  
**Max Use:** 10  
**Purpose:** To transmit information in a free-form format, if necessary, for comment or special instruction.  
**Syntax:** N/A  
**Semantic:** N/A  
**Comments:** N/A

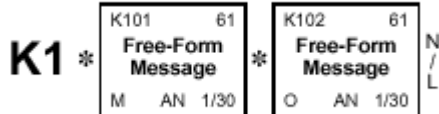

**Data Element Summary**

REF. DES.	DATA ELEMENT	NAME	ATTRIBUTES
K101	61	<b>Free Form Information</b> Free-form information.	M AN 1/30
		<b>Valid fixed format data is:</b>	
		<b>Entity Number</b> A code representing the bill of lading sequence Number (shipment control number), equipment Number, house bill number (bill control number) Used to control a consolidated shipment or other number On which the error occurred.	M AN 1/26
		<b>Location Identifier</b> Census Schedule D code representing the CBP port of first arrival	M N 4/4
K102	61	<b>Free Form Information</b> Free-form information.	O AN 1/30
		<b>A narrative explaining the error</b>	
		<b>Valid fixed format data is:</b>	
		<b>Error Code</b> A code defining the error taken from the error Data Dictionary	M N 3/3
		<b>Narrative</b> A free form definition of the error code from the Error Data Dictionary	M AN 27/27

A complete list of error codes and definitions is in the Appendix

MOTOR TRANSPORTATION INDUSTRY APPLICATIONS  
**CUSTOMS MANIFEST ACCEPTANCE/REJECTION**

Version 15 - Updated 2/14/2023

**Segment:** **M11** Manifest Bill of Lading Details

**Position:** 0900

**Loop:** M11

**Level:** Heading

**Usage:** Optional

**Max Use:** 1

**Purpose:** To transmit bill of lading detail information for a manifest

**Syntax:**

- 3 P0304**  
If either M1103 or M1104 is present, then the other is required.
- 5 P0506**  
If either M1105 or M1106 is present, then the other is required.
- 7 P0708**  
If either M1107 or M1108 is present, then the other is required.
- 11 P1113**  
If either M1111 or M1113 is present, then the other is required.
- 15 C1514**  
If M1115 is present, then M1114 is required.
- 18 C1815**  
If M1118 is present, then M1115 is required.
- 19 C1918**  
If M1119 is present, then M1118 is required.

**Semantic:**

- 1** M1101 is the unique bill of lading number. .
- 2** M1102 is used for Port of Lading (5-Digit Numeric Census Schedule K)
- 3** M1103 is used for total number of pieces on a bill of lading using the smallest package unit (maximum eight digits).
- 4** M1104 is the smallest package unit code.
- 11** M1111 is house bill number for consolidation.
- 12** M1112 is the unique bill of lading issuer code.
- 13** M1113 is the issuer code of the consolidated shipment.
- 14** M1114 is the code of the secondary party nominated to receive bill of lading status notifications.
- 15** M1115 is the code of the 2nd secondary party nominated to receive bill of lading status notifications.
- 18** M1118 is the Standard Carrier Alpha Code (SCAC) of an additional second notify carrier.
- 19** M1119 is the Standard Carrier Alpha Code (SCAC) of an additional second notify carrier.
- 20** M1120 is the last place/port prior to loading.
- 21** M1121 is the first foreign port.
- 22** M1122 identifies mode of transportation from the last place/port prior to loading.
- 23** M1123 is the method of payment for transportation.
- 24** M1124 is the Maritime Administration Cargo Preference Program Code (see code source 926).

**Comments:** **A** If identifying the US Customs bill number, the maximum length shall be 12.  
 .If identifying the Canadian cargo control number, the maximum length shall be 25.

MOTOR TRANSPORTATION INDUSTRY APPLICATIONS  
 CUSTOMS MANIFEST ACCEPTANCE/REJECTION  
 Version 15 - Updated 2/14/2023

<b>M11</b> *	M1101 598 <b>BOL/Waybill Number</b> M AN 1/25	M1102 310 <b>Location Identifier</b> M AN 1/30	M1103 380 <del>Quantity</del> X R 1/15	M1104 599 <b>Manifest Unit Code</b> X ID 1/3	M1105 81 <del>Weight</del> X R 1/10	M1106 188 <del>Weight Unit Code</del> X ID 1/1
	M1107 183 <del>Volume</del> X R 1/8	M1108 184 <b>Volume Unit Qualifier</b> X ID 1/1	M1109 582 <b>BOL Type Code</b> O ID 2/2	M1110 600 <b>Place of Receipt</b> O AN 1/17	M1111 598 <b>BOL/Waybill Number</b> X AN 1/25	M1112 140 <b>SCAC</b> M ID 2/4
	M1113 140 <b>SCAC</b> X ID 2/4	M1114 140 <del>SCAC</del> X ID 2/4	M1115 140 <del>SCAC</del> X ID 2/4	M1116 1302 <del>Shipper's Exp Dec Req</del> O AN 1/2	M1117 1578 <del>Export Except Code</del> O ID 2/2	M1118 140 <b>SCAC</b> X ID 2/4
	M1119 140 <b>SCAC</b> O ID 2/4	M1120 310 <del>Location Identifier</del> O AN 1/30	M1121 310 <del>Location Identifier</del> O AN 1/30	M1122 91 <del>Transport Type Code</del> O ID 1/2	M1123 591 <del>Payment Method Code</del> O ID 3/3	M1124 1271 <del>Industry Code</del> O AN 1/30
	M1125 128 <b>Reference Number Qual</b> O ID 2/3	M1126 56 <b>Type of Serv Code</b> O ID 2/2	M1127 373 <b>Date</b> O DT 8/8	M1128 1073 <b>Yes/No Cond Resp Code</b> O ID 1/1		

**Data Element Summary**

REF. DES.	DATA ELEMENT	NAME	ATTRIBUTES
M1101	598	<b>Bill of Lading/Waybill Number</b> Identification number assigned to the shipment by the carrier or consolidator.	M AN 1/25
M1102	310	<b>Location Identifier</b> Code which identifies a specific location.	O AN 1/30
M1109	582	<b>Bill of Lading Type Code</b> Code identifying the type of bill of lading.	O ID 2/2
M1110	600	<b>Place of Receipt by Pre-carrier</b> The city or country in which the pre-carrier took possession of the cargo.	O AN 1/17
M1111	598	<b>Bill of Lading/Waybill Number</b>	X AN 1/25
M1112	140	<b>Standard Carrier Alpha Code</b> Standard Carrier Alpha Code	M ID 2/4
M1113	140	<b>Standard Carrier Alpha Code</b> Standard Carrier Alpha Code	X ID 2/4
M1125	128	<b>Reference Number Qualifier</b> Code qualifying the reference identifier .	X ID 2/3
M1126	284	<b>Service Level Type</b> Code indicating extent of transportation service requested.	O ID 2/2
M1127	373	<b>Date</b> Date expressed as CCYYMMDD where CC represents the first two digits of the calendar year.	M DT 8/8
M1128	1073	<b>Yes/No Condition Response Code</b> Code indicating a Yes or No condition or response.	O ID 1/1



**Segment:** K1 Remarks  
**Position:** 1000  
**Loop:** N/A  
**Level:** Heading  
**Usage:** Optional  
**Max Use:** 10  
**Purpose:** To transmit information in a free-form format, if necessary, for comment or special instruction.  
**Syntax:** N/A  
**Semantic:** N/A  
**Comments:** N/A

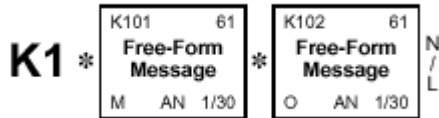

**Data Element Summary**

REF. DES.	DATA ELEMENT	NAME	ATTRIBUTES
K101	61	<b>Free Form Information</b> Free-form information.	<b>M AN 1/30</b>
<b>Valid fixed format data is:</b>			
		<b>Entity Number</b> A code representing the bill of lading sequence Number (shipment control number), equipment Number, house bill number (bill control number) Used to control a consolidated shipment or other number On which the error occurred.	<b>M AN 1/26</b>
		<b>Location Identifier</b> Census Schedule D code representing the CBP port of first arrival	<b>M N 4/4</b>
K102	61	<b>Free Form Information</b> Free-form information.	<b>O AN 1/30</b>
<b>A narrative explaining the error</b>			
<b>Valid fixed format data is:</b>			
		<b>Error Code</b> A code defining the error taken from the error Data Dictionary	<b>M N 3/3</b>
		<b>Narrative</b> A free form definition of the error code from the Error Data Dictionary	<b>M AN 27/27</b>

A complete list of error codes and definitions is in the Appendix

MOTOR TRANSPORTATION INDUSTRY APPLICATIONS  
**CUSTOMS MANIFEST ACCEPTANCE/REJECTION**

Version 15 - Updated 2/14/2023

**Segment:** **N9** Extended Reference Identification  
**Position:** 1050  
**Loop:** N9  
**Level:** Heading  
**Usage:** Optional  
**Max Use:** 999  
**Purpose:** To transmit information as specified by the reference identification qualifier  
**Syntax:** **2 R0203**  
 At least one of N902 or N903 is required.  
**6 C0605**  
 If N906 is present, then N905 is required.  
**3** If either C04003 or C04004 is present, then the other is required.  
**5** If either C04005 or C04006 is present, then the other is required.  
**Semantic:** **6** N906 reflects the time zone which the time reflects.  
**7** N907 contains data relating to the value cited in N902.  
**Comments:** N/A



**Data Element Summary**

REF. DES.	DATA ELEMENT	NAME	ATTRIBUTES
<b>N901</b>	<b>128</b>	<b>Reference Number Qualifier</b>	<b>M ID 2/3</b>
		Code qualifying the Reference Identifier	
<b>N902</b>	<b>127</b>	<b>Reference Identification</b>	<b>X AN 1/50</b>
		Reference identification as defined for a particular Transaction Set, or as specified by the Reference Identification Qualifier. (For CBP)	

MOTOR TRANSPORTATION INDUSTRY APPLICATIONS  
**CUSTOMS MANIFEST ACCEPTANCE/REJECTION**

Version 15 - Updated 2/14/2023

**Segment:** K1 Remarks  
**Position:** 1000  
**Loop:** N9  
**Level:** Heading  
**Usage:** Optional  
**Max Use:** 10  
**Purpose:** To transmit information in a free-form format, if necessary, for comment or special instruction.  
**Syntax:** N/A  
**Semantic:** N/A  
**Comments:** N/A

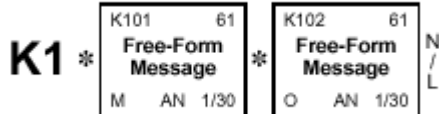

**Data Element Summary**

REF. DES.	DATA ELEMENT	NAME	ATTRIBUTES
K101	61	<b>Free Form Information</b> Free-form information.	M AN 1/30
<b>Valid fixed format data is:</b>			
		<b>Entity Number</b> A code representing the bill of lading sequence Number (shipment control number), equipment Number, house bill number (bill control number) Used to control a consolidated shipment or other number On which the error occurred.	M AN 1/26
		<b>Location Identifier</b> Census Schedule D code representing the CBP port of first arrival	M N 4/4
K102	61	<b>Free Form Information</b> Free-form information. <b>A narrative explaining the error</b> <b>Valid fixed format data is:</b>	O AN 1/30
		<b>Error Code</b> A code defining the error taken from the error Data Dictionary	M N 3/3
		<b>Narrative</b> A free form definition of the error code from the Error Data Dictionary	M AN 27/27

A complete list of error codes and definitions is in the Appendix

MOTOR TRANSPORTATION INDUSTRY APPLICATIONS  
**CUSTOMS MANIFEST ACCEPTANCE/REJECTION**

Version 15 - Updated 2/14/2023

**Segment:** N1 Party Identification  
**Position:** 1100  
**Loop:** N1  
**Level:** Heading  
**Usage:** Optional  
**Max Use:** 1  
**Purpose:** To identify a party by type of organization, name and code  
**Syntax:** 2 R0203  
 At least one of N102 or N103 is required.  
 3 P0304  
 If either N103 or N104 is present, then the other is required.

**Semantic:** N/A  
**Comments:** A This segment, used alone, provides the most efficient method of providing organizational identification. To obtain this efficiency the "ID Code" (N104) must provide a key to the table maintained by the transaction processing party.  
 B N105 and N106 further define the type of entity in N101.

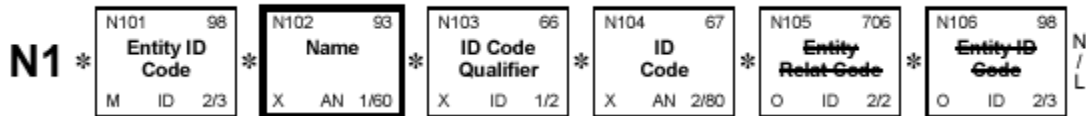

**Data Element Summary**

REF. DES.	DATA ELEMENT	NAME	ATTRIBUTES
N101	98	<b>Entity Identifier Code</b> Code identifying an organizational entity, a physical location, property, or an individual.	M ID 2/3
N102	93	<b>Name</b> Free-form name.	X AN 1/60
N103	66	<b>Identification Code Qualifier</b> Code designating the system/method of code structure used for Identification	X ID 1/2
N104	67	<b>Identification Code</b> Code identifying a party or other code.	X AN 2/80

MOTOR TRANSPORTATION INDUSTRY APPLICATIONS  
**CUSTOMS MANIFEST ACCEPTANCE/REJECTION**

Version 15 - Updated 2/14/2023

**Segment:** K1 Remarks  
**Position:** 1200  
**Loop:** N1  
**Level:** Heading  
**Usage:** Optional  
**Max Use:** 10  
**Purpose:** To transmit information in a free-form format, if necessary, for comment or special instruction.  
**Syntax:** N/A  
**Semantic:** N/A  
**Comments:** N/A

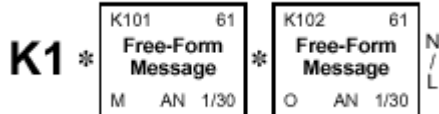

**Data Element Summary**

REF. DES.	DATA ELEMENT	NAME	ATTRIBUTES
K101	61	<b>Free Form Information</b> Free-form information.	M AN 1/30
<b>Valid fixed format data is:</b>			
		<b>Entity Number</b> A code representing the bill of lading sequence Number (shipment control number), equipment Number, house bill number (bill control number) Used to control a consolidated shipment or other number On which the error occurred.	M AN 1/26
		<b>Location Identifier</b> Census Schedule D code representing the CBP port of first arrival	M N 4/4
K102	61	<b>Free Form Information</b> Free-form information.	O AN 1/30
<b>A narrative explaining the error</b>			
<b>Valid fixed format data is:</b>			
		<b>Error Code</b> A code defining the error taken from the error Data Dictionary	M N 3/3
		<b>Narrative</b> A free form definition of the error code from the Error Data Dictionary	M AN 27/27

A complete list of error codes and definitions is in the Appendix

MOTOR TRANSPORTATION INDUSTRY APPLICATIONS  
**CUSTOMS MANIFEST ACCEPTANCE/REJECTION**

Version 15 - Updated 2/14/2023

**Segment:** N3 Party Location  
**Position:** 1300  
**Loop:** N3  
**Level:** Heading  
**Usage:** Optional  
**Max Use:** 1  
**Purpose:** To specify the location of the named party  
**Syntax:** N/A  
**Semantic:** N/A  
**Comments:** N/A

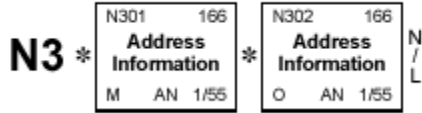

**Data Element Summary**

REF. DES.	DATA ELEMENT	NAME			ATTRIBUTES
N301	166	Address Information	M	AN	1/55
		Address information			
N302	166	Address Information	O	AN	1/55
		Address information			

**Segment:** K1 Remarks  
**Position:** 1400  
**Loop:** N3  
**Level:** Heading  
**Usage:** Optional  
**Max Use:** 10  
**Purpose:** To transmit information in a free-form format, if necessary, for comment or special instruction.  
**Syntax:** N/A  
**Semantic:** N/A  
**Comments:** N/A

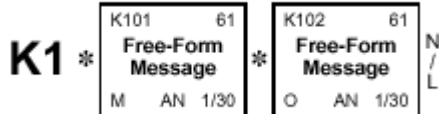

**Data Element Summary**

REF. DES.	DATA ELEMENT	NAME	ATTRIBUTES
K101	61	<b>Free Form Information</b> Free-form information.	M AN 1/30
<b>Valid fixed format data is:</b>			
		<b>Entity Number</b> A code representing the bill of lading sequence Number (shipment control number), equipment Number, house bill number (bill control number) Used to control a consolidated shipment or other number On which the error occurred.	M AN 1/26
		<b>Location Identifier</b> Census Schedule D code representing the CBP port of first arrival	M N 4/4
K102	61	<b>Free Form Information</b> Free-form information. <b>A narrative explaining the error</b>	O AN 1/30
<b>Valid fixed format data is:</b>			
		<b>Error Code</b> A code defining the error taken from the error Data Dictionary	M N 3/3
		<b>Narrative</b> A free form definition of the error code from the Error Data Dictionary	M AN 27/27

A complete list of error codes and definitions is in the Appendix

MOTOR TRANSPORTATION INDUSTRY APPLICATIONS  
**CUSTOMS MANIFEST ACCEPTANCE/REJECTION**

Version 15 - Updated 2/14/2023

**Segment:** N4 Geographic Location  
**Position:** 1410  
**Loop:** N4  
**Level:** Heading  
**Usage:** Optional  
**Max Use:** 1  
**Purpose:** To specify the geographic place of the named party  
**Syntax:** 2 E0207

Only one of N402 or N407 may be present.

**6 C0605**

If N406 is present, then N405 is required.

**7 C0704**

If N407 is present, then N404 is required.

**Comments:** A A combination of either N401 through N404 (or N405 and N406) may be adequate to specify a location.

B N402 is required only if city name (N401) is in the U.S. or Canada

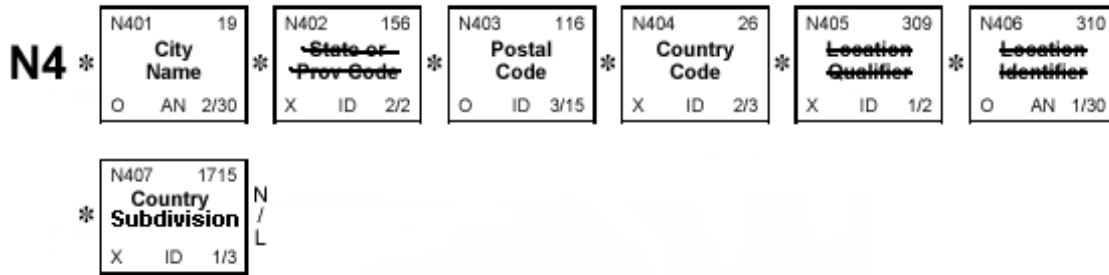

**Data Element Summary**

REF. DES.	DATA ELEMENT	NAME	ATTRIBUTES
N401	19	<b>City Name</b> Free-form text for city name.	O AN 2/30
N403	116	<b>Postal Code</b> Code defining international postal zone code excluding punctuation and blanks.	O ID 3/15
N404	26	<b>Country Code</b> Code identifying the country	X ID 2/3
N407	1715	<b>Country Subdivision</b> Code identifying the country subdivision	X ID 1/3



MOTOR TRANSPORTATION INDUSTRY APPLICATIONS  
**CUSTOMS MANIFEST ACCEPTANCE/REJECTION**

Version 15 - Updated 2/14/2023

**Segment:** K1 Remarks  
**Position:** 1420  
**Loop:** N4  
**Level:** Heading  
**Usage:** Optional  
**Max Use:** 10  
**Purpose:** To transmit information in a free-form format, if necessary, for comment or special instruction.  
**Syntax:** N/A  
**Semantic:** N/A  
**Comments:** N/A

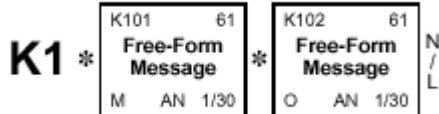

**Data Element Summary**

REF. DES.	DATA ELEMENT	NAME	ATTRIBUTES
K101	61	<b>Free Form Information</b> Free-form information.	M AN 1/30
		<b>Valid fixed format data is:</b>	
		<b>Entity Number</b> A code representing the bill of lading sequence Number (shipment control number), equipment Number, house bill number (bill control number) Used to control a consolidated shipment or other number On which the error occurred.	M AN 1/26
		<b>Location Identifier</b> Census Schedule D code representing the CBP port of first arrival	M N 4/4
K102	61	<b>Free Form Information</b> Free-form information.	O AN 1/30
		<b>A narrative explaining the error</b>	
		<b>Valid fixed format data is:</b>	
		<b>Error Code</b> A code defining the error taken from the error Data Dictionary	M N 3/3
		<b>Narrative</b> A free form definition of the error code from the Error Data Dictionary	M AN 27/27

A complete list of error codes and definitions is in the Appendix

MOTOR TRANSPORTATION INDUSTRY APPLICATIONS  
**CUSTOMS MANIFEST ACCEPTANCE/REJECTION**

Version 15 - Updated 2/14/2023

**Segment:** PER Administrative Communications Contact

**Position:** 1440

**Loop:** PER

**Usage:** Optional

**Max Use:** 1

**Semantic:** N/A

**Comments:** N/A

**Purpose:** To identify a person or office to whom administrative communications should be directed

**Syntax:** 3 P0304

If either PER03 or PER04 is present, then the other is required.

5 P0506

If either PER05 or PER06 is present, then the other is required.

7 P0708

If either PER07 or PER08 is present, then the other is required.

**Semantic:** N/A

**Comments:** N/A

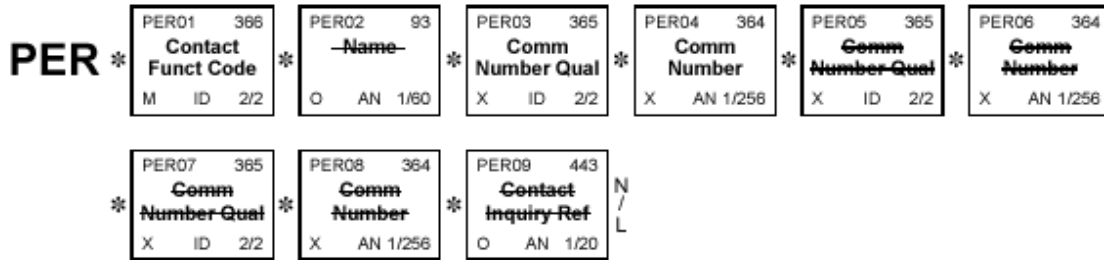

**Data Element Summary**

REF. DES.	DATA ELEMENT	NAME	ATTRIBUTES
PER01	366	Contact Function Code	M ID 2/2
PER03	365	Communication Number Qualifier	X ID 2/2
PER04	364	Communication Number	X AN 1/256

Code identifying the major duty or responsibility of the person or group named  
 Code identifying the type of communication number.  
 Complete communications number including country or area code when applicable.

MOTOR TRANSPORTATION INDUSTRY APPLICATIONS  
**CUSTOMS MANIFEST ACCEPTANCE/REJECTION**

Version 15 - Updated 2/14/2023

**Segment:** K1 Remarks  
**Position:** 1450  
**Loop:** PER  
**Level:** Heading  
**Usage:** Optional  
**Max Use:** 10  
**Purpose:** To transmit information in a free-form format, if necessary, for comment or special instruction.  
**Syntax:** N/A  
**Semantic:** N/A  
**Comments:** N/A

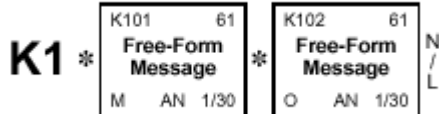

**Data Element Summary**

REF. DES.	DATA ELEMENT	NAME	ATTRIBUTES
K101	61	<b>Free Form Information</b> Free-form information.	M AN 1/30
<b>Valid fixed format data is:</b>			
		<b>Entity Number</b> A code representing the bill of lading sequence Number (shipment control number), equipment Number, house bill number (bill control number) Used to control a consolidated shipment or other number On which the error occurred.	M AN 1/26
		<b>Location Identifier</b> Census Schedule D code representing the CBP port of first arrival	M N 4/4
K102	61	<b>Free Form Information</b> Free-form information.	O AN 1/30
<b>A narrative explaining the error</b>			
<b>Valid fixed format data is:</b>			
		<b>Error Code</b> A code defining the error taken from the error Data Dictionary	M N 3/3
		<b>Narrative</b> A free form definition of the error code from the Error Data Dictionary	M AN 27/27

A complete list of error codes and definitions is in the Appendix

MOTOR TRANSPORTATION INDUSTRY APPLICATIONS  
**CUSTOMS MANIFEST ACCEPTANCE/REJECTION**

Version 15 - Updated 2/14/2023

**Segment:** M12 In-bond Identifying Information

**Position:** 1500

**Loop:** M12

**Level:** Heading

**Usage:** Optional

**Max Use:** 1

**Purpose:** To transmit in-bond information.

**Syntax:** 2 E0206  
 Only one of M1202 or M1206 may be present.

2 C0608  
 If M1206 is present, then M1208 is required.

3 P0809  
 If either M1208 or M1209 is present, then the other is required.

4 P1011  
 If either M1210 or M1211 is present, then the other is required.

**Semantic:** 3 M1203 is a 4-digit numeric census schedule D when identifying a U.S. port, and three-digit memorandum D when identifying a Canadian port. It is the port of destination if M1201 is 61. It is the port of export if M1201 is 62 or 63.

4 M1204 is 5-digit numeric census schedule K. It is the foreign port of destination if M1201 is 62 or 63.

7 M1207 identifies the carrier to whom liability is transferred.

12 M1212 is the US Food and Drug Administration prior notification requirement indicator. A "Y" indicates that the shipper has advised the commodity is subject to the prior notification requirement. An "N" indicates the commodity is not subject to the prior notification requirement. If blank, the default value is "N".

13 M1213 is the estimated date of departure of the in-bond shipment from the U.S.

14 M1214 is the FIRMS (Facilities Information Resources Management System) code of the location of the in-bond shipment.

**Comments:** A If M1202 does not contain the paperless entry number, then M1206 is required when used for US In-Bond information.

B M1205 is the value in whole dollars of the in-bond movement. Use twenty dollars per kilo if value is unknown.

<b>M12</b> *	M1201 581 <b>Entry Type Code</b> M ID 2/2	M1202 601 <b>Entry Number</b> X AN 1/15	M1203 310 <b>Location Identifier</b> O AN 1/30	M1204 310 <b>Location Identifier</b> O AN 1/30	M1205 602 <del>Customs Shipm Value</del> O AN 2/8	M1206 603 <b>In-Bond Ctrl Number</b> X AN 1/25
	* M1207 140 <b>SCAC</b> O ID 2/4	* M1208 128 <b>Reference Number Qual</b> X ID 2/3	* M1209 127 <b>Reference Identifctn</b> X AN 1/50	* M1210 91 <del>Transport Type Code</del> X ID 1/2	* M1211 182 <del>Vessel Name</del> X AN 2/28	* M1212 1073 <b>Yes/No Cond Resp Code</b> O ID 1/1
	* M1213 373 <b>Date</b> O DT 8/8	* M1214 310 <b>Location Identifier</b> O AN 1/30	N / L			

MOTOR TRANSPORTATION INDUSTRY APPLICATIONS  
**CUSTOMS MANIFEST ACCEPTANCE/REJECTION**  
 Version 15 - Updated 2/14/2023

**Data Element Summary**

REF. DES.	DATA ELEMENT	NAME	ATTRIBUTES	
M1201	581	<b>Customs Entry Type Code</b> Code defining the type of entry assigned by CBP..	M	ID 2/2
M1202	601	<b>Customs Entry Number</b> Automated Commercial System Code Furnished by U.S. Customs Service.	X	AN 1/15
M1203	310	<b>Location Identifier</b> Code which identifies a specific location.	O	AN 1/30
M1204	310	<b>Location Identifier</b> Code which identifies a specific location.	O	AN 1/30
M1206	603	<b>In-bond Control Number</b> Currently assigned control number for in-bond movement.	X	AN 1/25
M1207	140	<b>SCAC</b> Standard Carrier Alpha Code	O	ID 2/4
M1208	128	<b>Reference Number Qualifier</b> Code qualifying the Reference Identifier	X	ID 2/3
M1209	127	<b>Reference Identification</b> Reference information as defined for a particular Transaction Set, or as specified by the Reference Identification Qualifier.	X	AN 1/50
M1212	1073	<b>Yes/No Condition Response Code</b> Code indicating a Yes or No condition or response.	O	ID 1/1
M1213	373	<b>Date</b> Date expressed as CCYYMMDD	O	DT 8/8
M1214	310	<b>Location Identifier</b> Code which identifies a specific location.	O	AN 1/30

MOTOR TRANSPORTATION INDUSTRY APPLICATIONS  
**CUSTOMS MANIFEST ACCEPTANCE/REJECTION**

Version 15 - Updated 2/14/2023

**Segment:** K1 Remarks  
**Position:** 1510  
**Loop:** M12  
**Level:** Heading  
**Usage:** Optional  
**Max Use:** 10  
**Purpose:** To transmit information in a free-form format, if necessary, for comment or special instruction.  
**Syntax:** N/A  
**Semantic:** N/A  
**Comments:** N/A

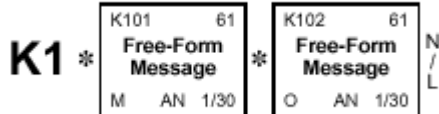

**Data Element Summary**

REF. DES.	DATA ELEMENT	NAME	ATTRIBUTES
K101	61	<b>Free Form Information</b> Free-form information.	M AN 1/30
<b>Valid fixed format data is:</b>			
		<b>Entity Number</b> A code representing the bill of lading sequence Number (shipment control number), equipment Number, house bill number (bill control number) Used to control a consolidated shipment or other number On which the error occurred.	M AN 1/26
		<b>Location Identifier</b> Census Schedule D code representing the CBP port of first arrival	M N 4/4
K102	61	<b>Free Form Information</b> Free-form information.	O AN 1/30
<b>A narrative explaining the error</b>			
<b>Valid fixed format data is:</b>			
		<b>Error Code</b> A code defining the error taken from the error Data Dictionary	M N 3/3
		<b>Narrative</b> A free form definition of the error code from the Error Data Dictionary	M AN 27/27

A complete list of error codes and definitions is in the Appendix

MOTOR TRANSPORTATION INDUSTRY APPLICATIONS  
**CUSTOMS MANIFEST ACCEPTANCE/REJECTION**

Version 15 - Updated 2/14/2023

**Segment:** M21 Supplementary In-Bond Information

**Position:** 1570

**Loop:** M21

**Level:** Heading

**Usage:** Optional

**Max Use:** 1

**Purpose:** To transmit data relating to a CBP in-bond movement

**Syntax:** 1 P0506

If either M2105 or M2106 is present, then the other is required.

2 P0708

If either M2107 or M2108 is present, then the other is required.

3 P0910

If either M2109 or M2110 is present, then the other is required.

4 P1415

If either M2114 or M2115 is present, then the other is required.

**Semantic:**

- 1 M2101 is the existing In-Bond Type Code
- 2 M2102 is the new port of destination code
- 3 M2103 is the unique bill of lading issuer code
- 4 M2104 is the unique bill of lading number
- 5 M2107 is the issuer code for the house bill of lading
- 6 M2108 is the bill of lading number for the house bill of lading
- 7 M2109 is the issuer code for the sub house bill of lading
- 8 M2110 is the bill of lading number for the sub house bill of lading number
- 9 M2111 is the first secondary notify party
- 10 M2112 is the second secondary notify party
- 11 M2113 is the manifest quantity involved in the in-bond movement
- 12 M2114 carries the additional bonded carrier information for a subsequent bonded cargo movement, beyond the intended destination of the first in-bond movement.

**Comments:** This segment is in the 357 set which is not currently used in truck AMS

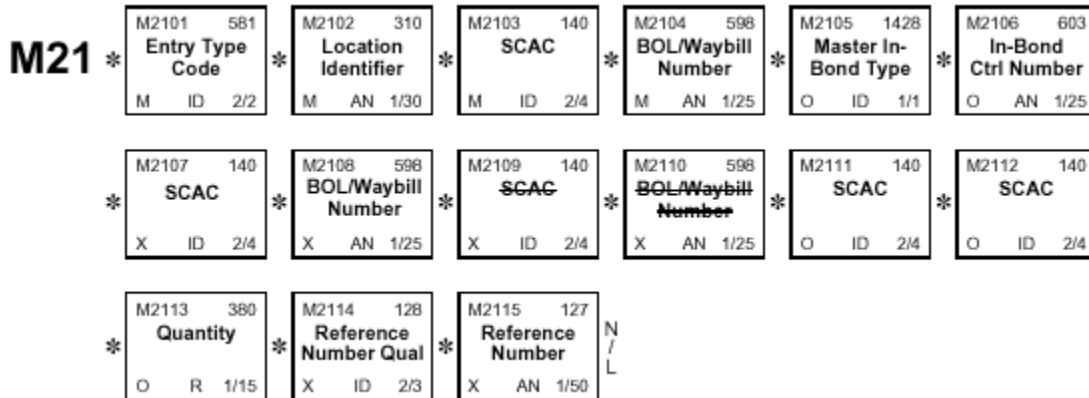

**Data Element Summary**

REF. DES.	DATA ELEMENT	NAME	ATTRIBUTES
M2101	581	<b>Entry Type Code</b> Code defining the type of entry assigned by U.S. Customs.	M ID 2/2
M2102	310	<b>Location Identifier</b> Code which identifies a specific location.	M AN 1/30
M2103	140	<b>Standard Carrier Alpha Code</b> Standard Carrier Alpha Code	M ID 2/4
M2104	598	<b>BOL/Waybill Number</b> Identification number assigned to the shipment by the carrier or consolidator.	M AN 1/25
M2105	1428	<b>Master In-bond Type Code</b> Code identifying a type of Master In-Bond	O ID 1/1

MOTOR TRANSPORTATION INDUSTRY APPLICATIONS  
**CUSTOMS MANIFEST ACCEPTANCE/REJECTION**

Version 15 - Updated 2/14/2023

<b>M2106</b>	<b>603</b>	<b>In-bond Control Number</b>	<b>O</b>	<b>AN 1/25</b>
		Currently assigned control number for the movement		
<b>M2107</b>	<b>140</b>	<b>SCAC</b>	<b>X</b>	<b>ID 2/4</b>
		Standard Carrier Alpha Code		
<b>M2108</b>	<b>598</b>	<b>BOL/Waybill Number</b>		
		Identification number assigned to the shipment by the carrier or consolidator		
<b>M2111</b>	<b>140</b>	<b>Standard Carrier Alpha Code</b>	<b>O</b>	<b>ID 2/4</b>
		Standard Carrier Alpha Code		
<b>M2112</b>	<b>140</b>	<b>Standard Carrier Alpha Code</b>	<b>O</b>	<b>ID 2/4</b>
		Standard Carrier Alpha Code		
<b>M2113</b>	<b>380</b>	<b>Quantity</b>	<b>O</b>	<b>R 1/15</b>
		Numeric value of quantity.		
<b>M2114</b>	<b>128</b>	<b>Reference Number Qualifier</b>	<b>X</b>	<b>ID 2/3</b>
		Code qualifying the Reference Identifier		
<b>M2115</b>	<b>127</b>	<b>Reference Number</b>	<b>X</b>	<b>AN 1/50</b>
		Reference identification as defined for a particular Transaction Set, or as specified by the Reference Identification Qualifier.		



MOTOR TRANSPORTATION INDUSTRY APPLICATIONS  
**CUSTOMS MANIFEST ACCEPTANCE/REJECTION**

Version 15 - Updated 2/14/2023

**Segment:** K1 Remarks  
**Position:** 1580  
**Loop:** M21  
**Level:** Heading  
**Usage:** Optional  
**Max Use:** 10  
**Purpose:** To transmit information in a free-form format, if necessary, for comment or special instruction.  
**Syntax:** N/A  
**Semantic:** N/A  
**Comments:** N/A

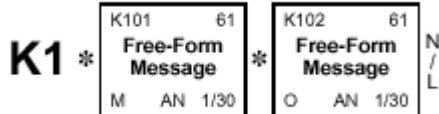

**Data Element Summary**

REF. DES.	DATA ELEMENT	NAME	ATTRIBUTES
K101	61	<b>Free Form Information</b> Free-form information.	M AN 1/30
		<b>Valid fixed format data is:</b>	
		Entity Number A code representing the bill of lading sequence Number (shipment control number), equipment Number, house bill number (bill control number) Used to control a consolidated shipment or other number On which the error occurred.	M AN 1/26
		Location Identifier Census Schedule D code representing the CBP port of first arrival	M N 4/4
K102	61	<b>Free Form Information</b> Free-form information. <b>A narrative explaining the error</b>	O AN 1/30
		<b>Valid fixed format data is:</b>	
		Error Code A code defining the error taken from the error Data Dictionary	M N 3/3
		Narrative A free form definition of the error code from the Error Data Dictionary	M AN 27/27

A complete list of error codes and definitions is in the Appendix

MOTOR TRANSPORTATION INDUSTRY APPLICATIONS  
**CUSTOMS MANIFEST ACCEPTANCE/REJECTION**

Version 15 - Updated 2/14/2023

**Segment:** M15 Customs Events Advisory Details

**Position:** 1630

**Loop:** M15

**Level:** Heading

**Usage:** Optional

**Max Use:** 1

**Purpose:** To notify Customs of in-bond cargo movement or of a conveyance arrival or departure, or of transfer of custodial liability when an in-bond movement involves multiple legs

**Syntax:** 1 R0410

At least one of M1504 or M1510 is required.

2 C1110

If M1511 is present, then M1510 is required.

3 P1314

If either M1513 or M1514 is present, then the other is required.

**Semantic:**

3 M1503 is the date of cargo movement, transfer of liability or conveyance arrival or departure

4 M1504 is the Schedule D code for place of cargo movement, transfer of liability or conveyance arrival or departure

5 M1505 is the unique bill of lading issuer code, required when M1501 is 2, 6 or B

6 M1506 is the time of cargo movement, transfer of liability or conveyance arrival or departure

8 M1508 is the Internal Revenue Service Identification number of the next in-bond carrier

9 M1509 is the Standard Carrier Alpha Code of the next in-bond carrier

10 M1510 is the city in which a transfer of custodial liability occurs

11 M1511 is the State or Province Code for the City named in M1510

12 If M1512 is 'Y', then M1504 is an intermediate port. If 'N', then M1504 is the port of final destination.

15 M1515 is the name of the exporting vessel.

17 M1517 is the last foreign port prior to sailing for the United States

**Comments:**

A For cargo arrival, export notifications or transfer of liability, M1502 can be an in-bond number, bill of lading number or container ID. For conveyance arrival and departures, M1502 will contain the voyage or trip number.

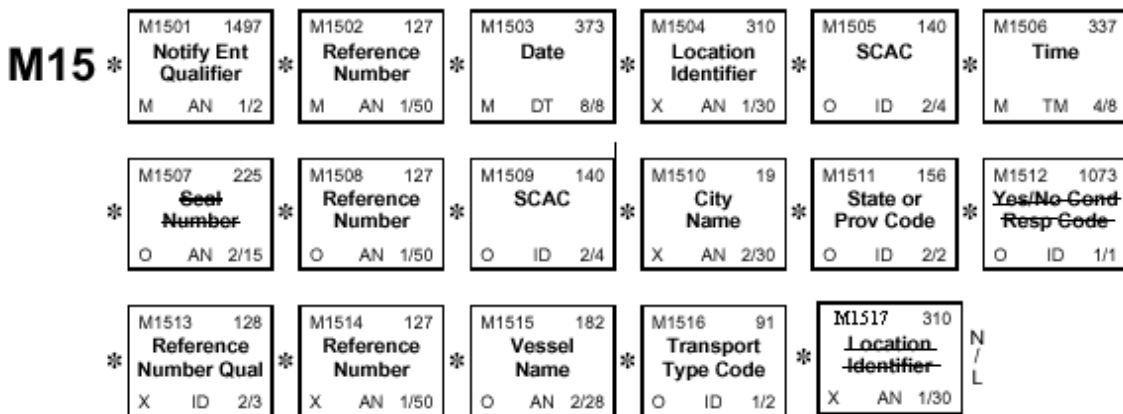

**Data Element Summary**

REF. DES.	DATA ELEMENT	NAME	ATTRIBUTES
M1501	1497	Notification Entity Qualifier Code indicating type of notifications	M AN 1/2
M1502	127	Reference Number Reference identification as defined for a particular Transaction Set, or as	M AN 1/50

MOTOR TRANSPORTATION INDUSTRY APPLICATIONS  
**CUSTOMS MANIFEST ACCEPTANCE/REJECTION**

Version 15 - Updated 2/14/2023

specified by the Reference Identification Qualifier.

<b>M1503</b>	<b>373</b>	<b>Date</b> Date expressed as CCYYMMDD where CC represents the first two digits of the calendar Year	<b>M</b>	<b>DT 8/8</b>
<b>M1504</b>	<b>310</b>	<b>Location Identifier</b> Code which identifies a specific location.	<b>X</b>	<b>AN 1/30</b>
<b>M1505</b>	<b>140</b>	<b>Standard Carrier Alpha Code</b> Standard Carrier Alpha Code	<b>O</b>	<b>ID 2/4</b>
<b>M1506</b>	<b>337</b>	<b>Time</b> Time expressed in 24-hour clock time as follows: HHMM, or HHMMSS, or HHMMSSDD, where H = hours (00-25), M=minutes (00-59), S = integer seconds, and DD= decimal seconds, decimal seconds are expressed as follows: D = tenths (0- 9) and DD = hundredths (00-99).	<b>M</b>	<b>TM 4/8</b>
<b>M1508</b>	<b>127</b>	<b>Reference Number</b> Reference identification as defined for a particular Transaction Set, or as specified by the Reference Identification Qualifier.	<b>O</b>	<b>AN 1/50</b>
<b>M1509</b>	<b>140</b>	<b>Standard Carrier Alpha Code</b> Standard Carrier Alpha Code	<b>O</b>	<b>ID 2/4</b>
<b>M1510</b>	<b>19</b>	<b>City Name</b> Free-form text for city name.	<b>X</b>	<b>AN 2/30</b>
<b>M1511</b>	<b>156</b>	<b>State or Province Code</b> Code (Standard State/Province) as defined by appropriate government agency.	<b>O</b>	<b>ID 2/2</b>
<b>M1513</b>	<b>128</b>	<b>Reference Number Qualifier</b> Code qualifying the Reference Identifier	<b>X</b>	<b>ID 2/3</b>
<b>M1514</b>	<b>127</b>	<b>Reference Number</b> Reference identification as defined for a particular Transaction Set, or as specified by the Reference Identification Qualifier.	<b>X</b>	<b>AN 1/50</b>
<b>M1515</b>	<b>182</b>	<b>Vessel Name</b> Name of ship as documented in "Lloyd's Register of Ships".	<b>O</b>	<b>AN 2/28</b>
<b>M1516</b>	<b>91</b>	<b>Transportation Method/Type Code</b> Code specifying the method or type of transportation for the shipment.	<b>O</b>	<b>ID 1/2</b>

MOTOR TRANSPORTATION INDUSTRY APPLICATIONS  
**CUSTOMS MANIFEST ACCEPTANCE/REJECTION**

Version 15 - Updated 2/14/2023

**Segment:** K1 Remarks  
**Position:** 1640  
**Loop:** M15  
**Level:** Heading  
**Usage:** Optional  
**Max Use:** 10  
**Purpose:** To transmit information in a free-form format, if necessary, for comment or special instruction.  
**Syntax:** N/A  
**Semantic:** N/A  
**Comments:** N/A

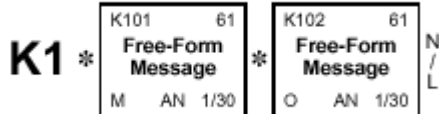

**Data Element Summary**

REF. DES.	DATA ELEMENT	NAME	ATTRIBUTES
K101	61	<b>Free Form Information</b> Free-form information.	M AN 1/30
<b>Valid fixed format data is:</b>			
		<b>Entity Number</b> A code representing the bill of lading sequence Number (shipment control number), equipment Number, house bill number (bill control number) Used to control a consolidated shipment or other number On which the error occurred.	M AN 1/26
		<b>Location Identifier</b> Census Schedule D code representing the CBP port of first arrival	M N 4/4
K102	61	<b>Free Form Information</b> Free-form information.	O AN 1/30
<b>A narrative explaining the error</b>			
<b>Valid fixed format data is:</b>			
		<b>Error Code</b> A code defining the error taken from the error Data Dictionary	M N 3/3
		<b>Narrative</b> A free form definition of the error code from the Error Data Dictionary	M AN 27/27

A complete list of error codes and definitions is in the Appendix

MOTOR TRANSPORTATION INDUSTRY APPLICATIONS  
**CUSTOMS MANIFEST ACCEPTANCE/REJECTION**

Version 15 - Updated 2/14/2023

- Segment:** VID Vehicle ID
- Position:** 1700  
**Loop:** VID  
**Level:** N/A  
**Usage:** Optional  
**Max Use:** 1  
**Purpose:** To identify a conveyance and its attributes.  
**Syntax:** **14 L141518**  
 If either VID14 or VID15 (VID18) is present, then the other is required.  
**15 E1518**  
 Only one of VID15 or VID18 may be present  
**15 C1516**  
 If VID15 is present then VID16 is required.  
**16 L161518**  
 If VID16 is present, then at least one of VID15 or VID18 is required.  
**18 C1816**  
 If VID18 is present, then VID16 is required.
- Semantic:** **12** VID12 is the Census Schedule K Code for the foreign port of loading on a vessel.  
**13** VID13 is the Standard Carrier Alpha Code (SCAC) of the Haulage Rights Carrier.  
**14** VID14 is the license plate of the equipment  
**15** VID15 is the state or province of the license in VID14  
**16** VID16 is the country of the license in the VID15 or VID18  
**17** VID17 is the ACE (Automated Commercial Environment) ID of the Equipment identified in the VID03  
**18** VID18 is the country subdivision of the license in the VID14

**Comments:** N/A

<b>VID</b> *	VID01 40 Equipment Desc Code M ID 2/2	VID02 206 Equipment Initial O AN 1/4	VID03 207 Equipment Number M AN 1/15	VID04 225 Seal Number O AN 2/15	VID05 225 Seal Number O AN 2/15	VID06 567 Equipment Length O NO 4/5
*	VID07 65 Height O R 1/8	VID08 189 Width O R 1/8	VID09 24 Equipment Type O ID 4/4	VID10 322 Load/Empty Status Code O ID 1/1	VID11 56 Type of Serv Code O ID 2/2	VID12 310 Location Identifier O/Z AN 1/30
*	VID13 140 SCAC O/Z ID 2/4	VID14 127 Reference Identifictn O/Z AN 1/80	VID15 156 State or Prou Code X/Z ID 2/2	VID16 26 Country Code X/Z ID 2/3	VID17 127 Reference Identifictn O/Z AN 1/80	VID18 1715 Country Subdivisn X/Z ID 1/3

**Data Element Summary**

REF. DES.	DATA ELEMENT	NAME	ATTRIBUTES
VID01	40	<b>Equipment Description Code</b> Code identifying type of equipment used for shipment.	M ID 2/2
VID02	206	<b>Equipment Initial</b> Prefix or alphabetic part of an equipment unit's identifying number.	O AN 1/4
VID03	207	<b>Equipment Number</b> Sequencing or serial part of an equipment unit's identifying number (pure numeric form for equipment number is preferred).	M AN 1/15
VID10	322	<b>Load/Empty Status Indicator</b> Code which specifies the loaded condition of the transportation equipment.	O ID 1/1
VID14	127	<b>Reference Identification</b> Reference Identification as defined for a particular Transaction Set, or as specified by the Reference Identification Qualifier.	O/Z AN 1/80
VID16	26	<b>Country Code</b>	X/Z ID 2/3

004061CBP 355

MOTOR TRANSPORTATION INDUSTRY APPLICATIONS  
**CUSTOMS MANIFEST ACCEPTANCE/REJECTION**

Version 15 - Updated 2/14/2023

Code identifying the country. The 2 alpha ISO country code of the state/province in VID15

**VID17 127**

**Reference Identification**

**O/Z AN 1/50**

Reference Identification as defined for a particular Transaction Set, or as specified by the Reference Identification Qualifier.

**VID18 1715**

**Country Subdivision**

**X/Z ID 1/3**

Code identifying the country subdivision

MOTOR TRANSPORTATION INDUSTRY APPLICATIONS  
**CUSTOMS MANIFEST ACCEPTANCE/REJECTION**

Version 15 - Updated 2/14/2023

**Segment:** K1 Remarks  
**Position:** 1750  
**Loop:** VID  
**Level:** Heading  
**Usage:** Optional  
**Max Use:** 10  
**Purpose:** To transmit information in a free-form format, if necessary, for comment or special instruction.  
**Syntax:** N/A  
**Semantic:** N/A  
**Comments:** N/A

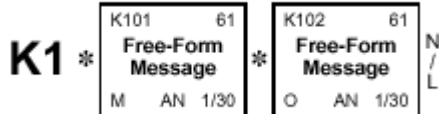

**Data Element Summary**

REF. DES.	DATA ELEMENT	NAME	ATTRIBUTES
K101	61	<b>Free Form Information</b> Free-form information.	M AN 1/30
		<b>Valid fixed format data is:</b>	
		<b>Entity Number</b> A code representing the bill of lading sequence Number (shipment control number), equipment Number, house bill number (bill control number) Used to control a consolidated shipment or other number On which the error occurred.	M AN 1/26
		<b>Location Identifier</b> Census Schedule D code representing the CBP port of first arrival	M N 4/4
K102	61	<b>Free Form Information</b> Free-form information.	O AN 1/30
		<b>A narrative explaining the error</b>	
		<b>Valid fixed format data is:</b>	
		<b>Error Code</b> A code defining the error taken from the error Data Dictionary	M N 3/3
		<b>Narrative</b> A free form definition of the error code from the Error Data Dictionary	M AN 27/27

A complete list of error codes and definitions is in the Appendix

MOTOR TRANSPORTATION INDUSTRY APPLICATIONS  
**CUSTOMS MANIFEST ACCEPTANCE/REJECTION**  
 Version 15 - Updated 2/14/2023

**Segment:** M7 Seal Numbers  
**Position:** 1755  
**Loop:** VID  
**Level:** Heading  
**Usage:** Optional  
**Max Use:** 1  
**Purpose:** To record seal numbers used and the organization that applied the seals.  
**Syntax:** N/A  
**Semantic:** N/A  
**Comments:** 5 M705 indicates the name of the organization who applied the seal(s)

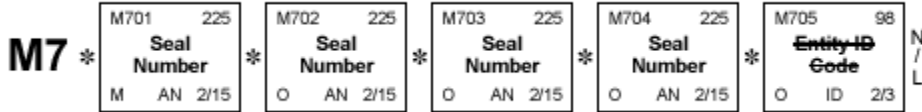

**Data Element Summary**

REF. DES.	DATA ELEMENT	NAME	ATTRIBUTES
M701	225	<b>Seal Number</b> Unique number on seal used to close a shipment.	M AN 2/15
M702	225	<b>Seal Number</b> Unique number on seal used to close a shipment.	O AN 2/15
M703	225	<b>Seal Number</b> Unique number on seal used to close a shipment.	O AN 2/15
M704	225	<b>Seal Number</b> Unique number on seal used to close a shipment.	O AN 2/15



**Segment:** K1 Remarks  
**Position:** 1757  
**Loop:** VID  
**Level:** Heading  
**Usage:** Optional  
**Max Use:** 10  
**Purpose:** To transmit information in a free-form format, if necessary, for comment or special instruction.  
**Syntax:** N/A  
**Semantic:** N/A  
**Comments:** N/A

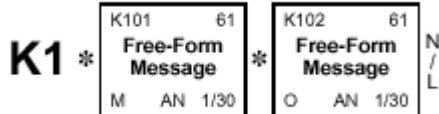

**Data Element Summary**

REF. DES.	DATA ELEMENT	NAME	ATTRIBUTES
K101	61	<b>Free Form Information</b> Free-form information.	M AN 1/30
		<b>Valid fixed format data is:</b>	
		Entity Number 'Not Applicable'	M AN 1/26
		Location Identifier Census Schedule D code representing the CBP port of first arrival	M N 4/4
K102	61	<b>Free Form Information</b> Free-form information.	O AN 1/30
		<b>A narrative explaining the error</b>	
		<b>Valid fixed format data is:</b>	
		Error Code A code defining the error taken from the error Data Dictionary	M N 3/3
		Narrative A free form definition of the error code from the Error Data Dictionary	M AN 27/27

A complete list of error codes and definitions is in the Appendix

MOTOR TRANSPORTATION INDUSTRY APPLICATIONS  
**CUSTOMS MANIFEST ACCEPTANCE/REJECTION**

Version 15 - Updated 2/14/2023

**Segment:** MBL Bill of Lading  
**Position:** 1760  
**Loop:** MBL  
**Level:** Header  
**Usage:** Optional  
**Max Use:** 1  
**Purpose:** To specify a bill of lading number and associated information.  
**Syntax:** N/A  
**Semantic:** 4 If MBL04 is 'Y', then issuer is an Automated Manifest System (AMS) participant. If 'N', then issuer is not an (AMS) participant.  
 6 MBL06 indicates the actual quantity boarded on the conveyance.  
 7 MBL07 is the Standard Carrier Alpha Code (SCAC) of the carrier issuing the house bill.  
 8 MBL08 is the bill of lading/waybill number submitted in the original 309.

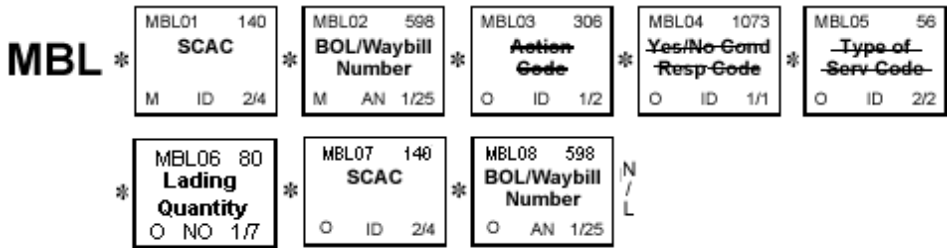

**Data Element Summary**

REF. DES	DATA ELEMENT	NAME	ATTRIBUTES
MBL01	140	<b>Standard Carrier Alpha Code</b> Standard Carrier Alpha Code	M ID 2/4
MBL02	598	<b>Bill of Lading/Waybill Number</b> Identification number assigned to the shipment by the carrier or consolidator.	M AN 1/25
MBL06	80	<b>Lading Quantity</b>	O NO 1/8
MBL07	140	<b>Standard Carrier Alpha Code</b> Standard Carrier Alpha Code	O ID 2/4
MBL08	598	<b>Bill of Lading/Waybill Number</b> Identification number assigned to the shipment by the carrier or consolidator.	O AN 1/25

MOTOR TRANSPORTATION INDUSTRY APPLICATIONS  
**CUSTOMS MANIFEST ACCEPTANCE/REJECTION**

Version 15 - Updated 2/14/2023

**Segment:** K1 Remarks  
**Position:** 1780  
**Loop:** MBL  
**Level:** Heading  
**Usage:** Optional  
**Max Use:** 10  
**Purpose:** To transmit information in a free-form format, if necessary, for comment or special instruction.  
**Syntax:** N/A  
**Semantic:** N/A  
**Comments:** N/A

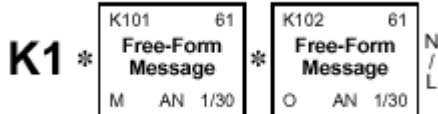

**Data Element Summary**

REF. DES.	DATA ELEMENT	NAME	ATTRIBUTES
K101	61	<b>Free Form Information</b> Free-form information.	M AN 1/30
		<b>Valid fixed format data is:</b>	
		Entity Number 'Not Applicable'	M AN 1/26
		Location Identifier Census Schedule D code representing the CBP port of first arrival	M N 4/4
K102	61	<b>Free Form Information</b> Free-form information.	O AN 1/30
		<b>A narrative explaining the error</b>	
		<b>Valid fixed format data is:</b>	
		Error Code A code defining the error taken from the error Data Dictionary	M N 3/3
		Narrative A free form definition of the error code from the Error Data Dictionary	M AN 27/27

A complete list of error codes and definitions is in the Appendix

MOTOR TRANSPORTATION INDUSTRY APPLICATIONS  
**CUSTOMS MANIFEST ACCEPTANCE/REJECTION**  
 Version 15 - Updated 2/14/2023

**Segment:** M13 Manifest Amendment Details  
**Position:** 1800  
**Loop:** M13  
**Level:** Heading  
**Usage:** Optional  
**Max Use:** 1  
**Purpose:** To correct a manifest record prior to vessel arrival or to amend a manifest record after vessel arrival.

**Syntax:** 1 P0810  
 If either M1308 or M1310 is present, then the other is required.  
 2 P1112  
 If either M1311 or M1312 is present, then the other is required.

**Semantic:** 1 M1301 is the Bill of Lading Issuer.  
 2 M1302 is used for discharge port (4-digit numeric census schedule D).  
 3 M1305 is new manifest quantity and is used if M1303 = "R"  
 8 M1308 is used to report individual portions of a consolidated shipment.  
 9 M1309 is the conveyance operator's Standard Carrier Alpha Code  
 10 M1310 is the issuer code for the consolidated shipment.

**Comments:** N/A

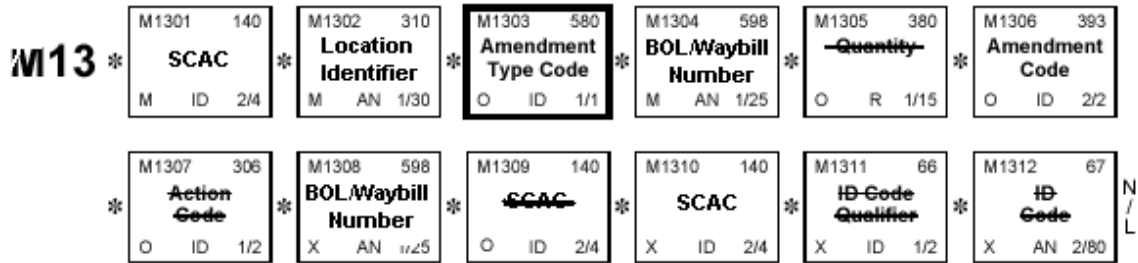

**Data Element Summary**

REF. DES.	DATA ELEMENT	NAME	ATTRIBUTES
M1301	140	<b>Standard Carrier Alpha Code</b> Standard Carrier Alpha Code	M ID 2/4
M1302	310	<b>Location Identifier</b> Code which identifies a specific location.	M AN 1/30
M1303	580	<b>Amendment Type Code</b> Code identifying type of manifest amendment.	O ID 1/1
M1304	598	<b>Bill of Lading/Waybill Number</b> Identification number assigned to the shipment by the carrier or consolidator.	M AN 1/25
M1306	393	<b>Amendment Code</b> Code giving the reasons for the amendment of the manifest record.	O ID 2/2
M1308	598	<b>Bill of lading/Waybill Number</b> Identification number assigned to the shipment by the carrier or consolidator.	X AN 1/25
M1310	140	<b>Standard Carrier Alpha Code</b> Standard Carrier Alpha Code	X ID 2/4

MOTOR TRANSPORTATION INDUSTRY APPLICATIONS  
**CUSTOMS MANIFEST ACCEPTANCE/REJECTION**

Version 15 - Updated 2/14/2023

**Segment:** K1 Remarks  
**Position:** 1850  
**Loop:** M13  
**Level:** Heading  
**Usage:** Optional  
**Max Use:** 10  
**Purpose:** To transmit information in a free-form format, if necessary, for comment or special instruction.  
**Syntax:** N/A  
**Semantic:** N/A  
**Comments:** N/A

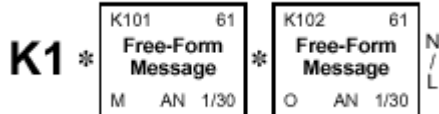

**Data Element Summary**

REF. DES.	DATA ELEMENT	NAME	ATTRIBUTES
K101	61	<b>Free Form Information</b> Free-form information.	M AN 1/30
<b>Valid fixed format data is:</b>			
		<b>Entity Number</b> A code representing the bill of lading sequence Number (shipment control number), equipment Number, house bill number (bill control number) Used to control a consolidated shipment or other number On which the error occurred.	M AN 1/26
		<b>Location Identifier</b> Census Schedule D code representing the CBP port of first arrival	M N 4/4
K102	61	<b>Free Form Information</b> Free-form information.	O AN 1/30
<b>A narrative explaining the error</b>			
<b>Valid fixed format data is:</b>			
		<b>Error Code</b> A code defining the error taken from the error Data Dictionary	M N 3/3
		<b>Narrative</b> A free form definition of the error code from the Error Data Dictionary	M AN 27/27

A complete list of error codes and definitions is in the Appendix

MOTOR TRANSPORTATION INDUSTRY APPLICATIONS  
**CUSTOMS MANIFEST ACCEPTANCE/REJECTION**

Version 15 - Updated 2/14/2023

**Segment:** N10 Quantity and Description

**Position:** 2000  
**Loop:** N10  
**Level:** Heading  
**Usage:** Optional  
**Max Use:** 1  
**Purpose:** To indicate line item quantity, description, marks and numbers, commodity code, weight and Customs value

**Syntax:** **4 P0405**  
 If either N1004 or N1005 is present, then the other is required.  
**6 P0613**  
 If either N1006 or N1013 is present, then the other is required.  
**7 P0708**  
 If either N1007 or N1008 is present, then the other is required.

**Semantic:** **9** N1009 is the CBP Bar Code Number for Line Release  
**11** N1011 is the country of manufacture of the goods  
**12** N1012 is the country of the final destination of the goods  
**13** N1013 is the currency of the value of the goods

**Comments:** N/A

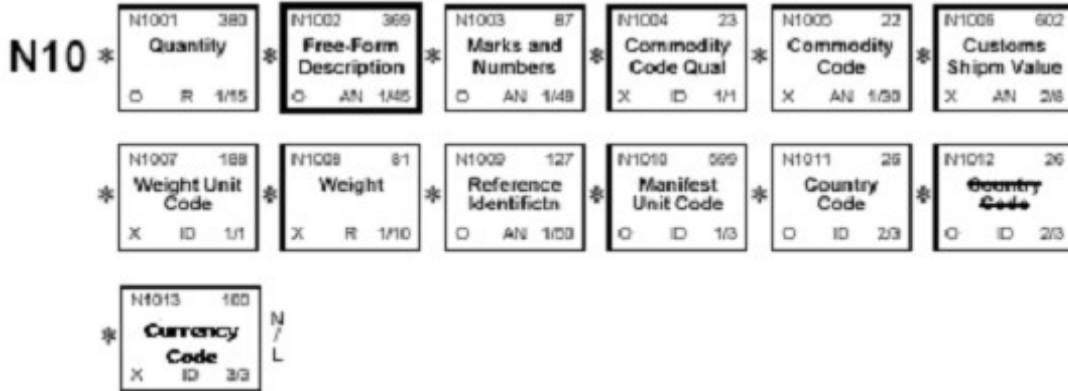

**Data Element Summary**

REF. DES.	DATA ELEMENT	NAME	ATTRIBUTES
N1001	380	<b>Quantity</b> Numeric value of quantity.	O R 1/15
N1002	369	<b>Free-form Description</b> Free-form descriptive text.	O AN 1/45
N1003	87	<b>Marks and Numbers</b> Marks and Numbers used to identify a shipment or parts of a shipment.	O AN 1/48
N1004	23	<b>Commodity Code Qualifier</b> Code identifying the commodity coding system used for Commodity Code.	X ID 1/1
N1005	22	<b>Commodity Code</b> Code describing a commodity or group of commodities.	X AN 1/30
N1006	602	<b>Customs Shipment Value</b> Customs value in whole dollars.	X AN 2/8
N1007	188	<b>Weight Unit Code</b> Code specifying the weight unit.	X ID 1/1
N1008	81	<b>Weight</b> Numeric value of weight .	X R 1/10
N1009	127	<b>Reference Identification</b> Reference identification as defined for a particular Transaction Set, or as specified by the Reference Identification Qualifier.	O AN 1/50
N1010	599	<b>Manifest Unit Code</b> Code defining the smallest package unit for the bill of lading.	O ID 1/3
N1011	26	<b>Country Code</b>	O ID 2/3

004061CBP 355

MOTOR TRANSPORTATION INDUSTRY APPLICATIONS  
**CUSTOMS MANIFEST ACCEPTANCE/REJECTION**

Version 15 - Updated 2/14/2023

**N1013 100**

Code identifying the country

**Currency Code**

**X ID 3/3**

Code (Standard ISO) for country in whose currency the charges are specified.

MOTOR TRANSPORTATION INDUSTRY APPLICATIONS  
**CUSTOMS MANIFEST ACCEPTANCE/REJECTION**

Version 15 - Updated 2/14/2023

**Segment:** K1 Remarks  
**Position:** 2050  
**Loop:** N10  
**Level:** Heading  
**Usage:** Optional  
**Max Use:** 10  
**Purpose:** To transmit information in a free-form format, if necessary, for comment or special instruction.  
**Syntax:** N/A  
**Semantic:** N/A  
**Comments:** N/A

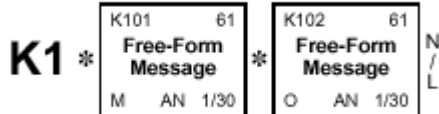

**Data Element Summary**

REF. DES.	DATA ELEMENT	NAME	ATTRIBUTES
K101	61	<b>Free Form Information</b> Free-form information.	M AN 1/30
		<b>Valid fixed format data is:</b>	
		<b>Entity Number</b> A code representing the bill of lading sequence Number (shipment control number), equipment Number, house bill number (bill control number) Used to control a consolidated shipment or other number On which the error occurred.	M AN 1/26
		<b>Location Identifier</b> Census Schedule D code representing the CBP port of first arrival	M N 4/4
K102	61	<b>Free Form Information</b> Free-form information.	O AN 1/30
		<b>A narrative explaining the error</b>	
		<b>Valid fixed format data is:</b>	
		<b>Error Code</b> A code defining the error taken from the error Data Dictionary	M N 3/3
		<b>Narrative</b> A free form definition of the error code from the Error Data Dictionary	M AN 27/27

A complete list of error codes and definitions is in the Appendix



MOTOR TRANSPORTATION INDUSTRY APPLICATIONS  
**CUSTOMS MANIFEST ACCEPTANCE/REJECTION**  
 Version 15 - Updated 2/14/2023

**Segment:** VC Motor Vehicle Control  
**Position:** 2100  
**Loop:** N10  
**Level:** Heading  
**Usage:** Optional  
**Max Length:** 134  
**Purpose:** To define motor vehicle identification and logistics.  
**Syntax:** N/A  
**Semantic:** 5 VC05 is the automotive manufacturer route code.  
 12 VC12 is the direction the headlights of the vehicle point  
 13 VC13 is the final destination ramp location as assigned by the manufacturer.  
**Comments:** N/A

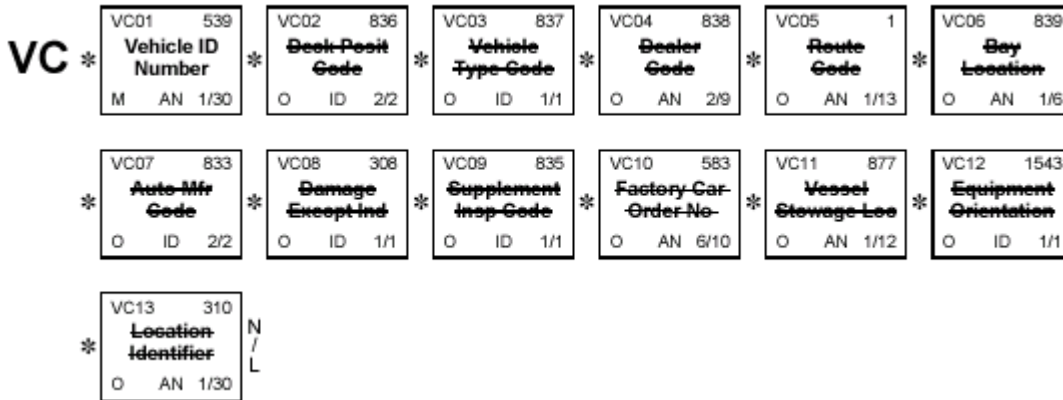

**Data Element Summary**

REF. DES.	DATA ELEMENT	NAME	ATTRIBUTES
VC01	539	Vehicle Identification Number	M AN 1/30
		Unique identification number stamped on the vehicle by the manufacturer.	

MOTOR TRANSPORTATION INDUSTRY APPLICATIONS  
**CUSTOMS MANIFEST ACCEPTANCE/REJECTION**

Version 15 - Updated 2/14/2023

**Segment:** K1 Remarks  
**Position:** 2150  
**Loop:** N10  
**Level:** Heading  
**Usage:** Optional  
**Max Use:** 10  
**Purpose:** To transmit information in a free-form format, if necessary, for comment or special instruction.  
**Syntax:** N/A  
**Semantic:** N/A  
**Comments:** N/A

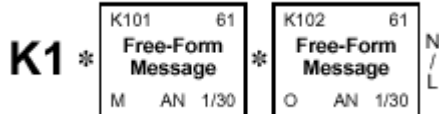

**Data Element Summary**

REF. DES.	DATA ELEMENT	NAME	ATTRIBUTES
K101	61	<b>Free Form Information</b> Free-form information.	M AN 1/30
<b>Valid fixed format data is:</b>			
		<b>Entity Number</b> A code representing the bill of lading sequence Number (shipment control number), equipment Number, house bill number (bill control number) Used to control a consolidated shipment or other number On which the error occurred.	M AN 1/26
		<b>Location Identifier</b> Census Schedule D code representing the CBP port of first arrival	M N 4/4
K102	61	<b>Free Form Information</b> Free-form information.	O AN 1/30
<b>A narrative explaining the error</b>			
<b>Valid fixed format data is:</b>			
		<b>Error Code</b> A code defining the error taken from the error Data Dictionary	M N 3/3
		<b>Narrative</b> A free form definition of the error code from the Error Data Dictionary	M AN 27/27

A complete list of error codes and definitions is in the Appendix

MOTOR TRANSPORTATION INDUSTRY APPLICATIONS  
**CUSTOMS MANIFEST ACCEPTANCE/REJECTION**

Version 15 - Updated 2/14/2023

**Segment:** H1 Hazardous Material  
**Position:** 2200  
**Loop:** H1  
**Level:** Heading  
**Usage:** Optional  
**Max Use:** 1  
**Purpose:** To specify information relative to hazardous material  
**Syntax:** 7 P0708  
 If either H107 or H108 is present, then the other is required.  
**Semantic:** N/A  
**Comments:** 1 This segment is required when the shipment contains hazardous material.  
 2 H107 is lowest temperature for hazardous materials.

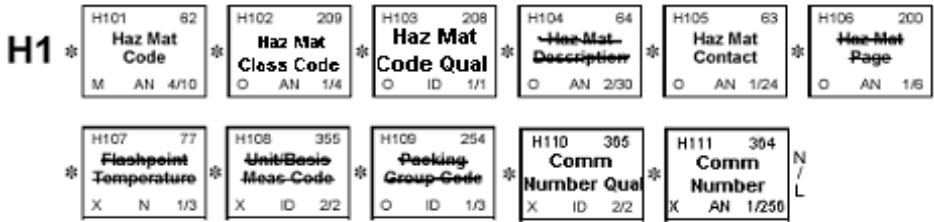

**Data Element Summary**

REF. DES.	DATA ELEMENT	NAME	ATTRIBUTES
H101	62	<b>Hazardous Material Code</b> Code relating to hazardous material code qualifier for regulated hazardous materials.	M AN 4/10
H102	209	<b>Hazardous Material Class Code</b> Code specifying the kind of hazard for a material.	O AN 1/4
H103	208	<b>Hazardous Material Code Qualifier</b> Code which qualifies the Hazardous Material Class Code (209)	O ID 1/1
H105	63	<b>Hazardous Material Contact</b> Name of person or department to contact in case of emergency.	O AN 1/24
H110	365	<b>Communication Number Qualifier</b> Code identifying the type of communication number	X ID 2/2
H111	364	<b>Communication Number</b> Complete Communication number including country or area code when Applicable. Truck manifest will accept only 30 positions.	X AN 1/256

MOTOR TRANSPORTATION INDUSTRY APPLICATIONS  
**CUSTOMS MANIFEST ACCEPTANCE/REJECTION**

Version 15 - Updated 2/14/2023

**Segment:** K1 Remarks  
**Position:** 1850  
**Loop:** H1  
**Level:** Heading  
**Usage:** Optional  
**Max Use:** 10  
**Purpose:** To transmit information in a free-form format, if necessary, for comment or special instruction.  
**Syntax:** N/A  
**Semantic:** N/A  
**Comments:** N/A

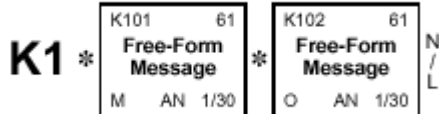

**Data Element Summary**

REF. DES.	DATA ELEMENT	NAME	ATTRIBUTES
K101	61	<b>Free Form Information</b> Free-form information.	M AN 1/30
		<b>Valid fixed format data is:</b>	
		<b>Entity Number</b> A code representing the bill of lading sequence Number (shipment control number), equipment Number, house bill number (bill control number) Used to control a consolidated shipment or other number On which the error occurred.	M AN 1/26
		<b>Location Identifier</b> Census Schedule D code representing the CBP port of first arrival	M N 4/4
K102	61	<b>Free Form Information</b> Free-form information.	O AN 1/30
		<b>A narrative explaining the error</b>	
		<b>Valid fixed format data is:</b>	
		<b>Error Code</b> A code defining the error taken from the error Data Dictionary	M N 3/3
		<b>Narrative</b> A free form definition of the error code from the Error Data Dictionary	M AN 27/27

A complete list of error codes and definitions is in the Appendix

MOTOR TRANSPORTATION INDUSTRY APPLICATIONS  
**CUSTOMS MANIFEST ACCEPTANCE/REJECTION**

Version 15 - Updated 2/14/2023

**Segment:** K3 Remarks  
**Position:** 0100  
**Loop:** N/A  
**Level:** Detail  
**Usage:** Mandatory  
**Max Use:** 1  
**Purpose:** To transmit a fixed-format record or matrix contents  
**Syntax:** N/A  
**Semantic:** 1 The K303 identifies the value of the index  
**Comments:** A The default for K302 is content

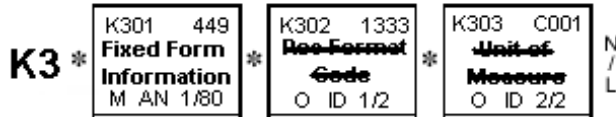

**Data Element Summary**

REF. DES.	DATA ELEMENT	NAME	ATTRIBUTES
K301	449	<b>Fixed Form Information</b> Free-form information.	M AN 1/80

		<b>SCAC</b> Standard Carrier Alpha code. Carrier instituting the manifest	M AN 4/4
		<b>Date of Transmission</b> The date in YYMMDD format representing the time the Original input transmission was processed	M N 6/6
		<b>Time of Transmission</b> The time in HHMMSS format representing the time The original input transmission was processed	M N 6/6
		<b>Total Manifests Read</b> The total number of manifests read on a single Transmission	O N 2/2
		<b>Total Ports Read</b> The total number of ports read in a single transmission	M N 3/3
		<b>Total Bills Read</b> The total number of bills read in a single transmission	M N 5/5
		<b>Total House Bills Read</b> The total number of house bills read in a single transmission	O N 5/5
		<b>Total Amendments Read</b> The total number of amendments read in a single Transmission	O N 5/5
		<b>Total number of M15 Segments (350 Set) Transmitted</b> The total number of M15 segments read in a single Transmission	O N 5/5
		<b>Total Bills/House Bills/Other Records rejected</b> The total number of records that were rejected in a Single transmission	O N 5/5
		<b>Total Bills/House Bills/Other Records Accepted</b> The total number of records that were accepted Into the database in a single transmission	O N 5/5

MOTOR TRANSPORTATION INDUSTRY APPLICATIONS  
CUSTOMS MANIFEST ACCEPTANCE/REJECTION

Version 15 - Updated 2/14/2023

<b>Total Records Read</b> The total number of records in a single Transmission	<b>M</b>	<b>N</b>	<b>5/5</b>
<b>Total Export Transaction Data Read</b> The total number of export transaction data That were read on a single transmission	<b>M</b>	<b>N</b>	<b>5/5</b>
<b>Total Export Transaction Data Rejected</b> The total number of export transaction data That were rejected for a single transmission	<b>O</b>	<b>N</b>	<b>5/5</b>
<b>Total Export Transaction Data Accepted</b> The total number of export transaction data that Were accepted for a single transaction	<b>O</b>	<b>N</b>	<b>5/5</b>

MOTOR TRANSPORTATION INDUSTRY APPLICATIONS  
**CUSTOMS MANIFEST ACCEPTANCE/REJECTION**

Version 15 - Updated 2/14/2023

**Segment:** SE Transaction Set Trailer  
**Position:** 0200  
**Loop:** N/A  
**Level:** Detail  
**Usage:** Mandatory  
**Max Use:** 1  
**Purpose:** To indicate the end of the transaction set and provide the count of the transmitted segments (including the beginning (ST) and ending (SE) segments).  
**Syntax:** N/A  
**Semantic:** N/A  
**Comments:** 1 SE is the last segment of each transaction set.

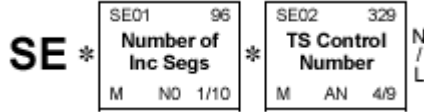

**Data Element Summary**

REF. DES.	DATA ELEMENT	NAME	ATTRIBUTES
SE01	96	<b>Number of Included Segments</b> Total number of segments included in a transaction set including ST and SE segments.	<b>M NO 1/10</b>
SE02	329	<b>Transaction Set Control Number</b> Identifying control number that must be unique within the transaction set functional group assigned by the originator for a transaction set	<b>M AN 4/9</b>

**ERROR APPENDIX**

- 003 No B01/M11 Record Found**  
No bill of lading/shipment control record found.  
Check for M11 segment.
- 004 Invalid S01/N1 Rec Found**  
Valid party identification was not transmitted.  
Check for N1 segment.
- 005 Invalid U01/N1 or N01/N1**  
Invalid party identification.  
Consignee or Notify Party name/address was not transmitted on  
N1 segment Consignee Name/Address record  
or  
N1 segment Notify Party Name/Address record.
- 009 Invalid Carrier Code**  
Carrier Code not active in CBP's carrier file.  
Verify carrier code and if necessary, email the SCAC issue to [amsscac@cbp.dhs.gov](mailto:amsscac@cbp.dhs.gov) along with NMFTA  
SCAC assignment/renewal letter or receipt.  
  
Transaction sets 309, 353, 358: M1001 – code missing or Invalid.
- 017 Missing or Invalid Bill**  
Bill of Lading sequence number / shipment control number is missing or too long.  
  
Transaction set 309: M1101 or M1304 is a bill of lading sequence number / shipment control number and  
cannot be blank or more than 12 characters.
- 020 Invalid Weight**  
Weight cannot be '0'  
  
Transaction set 309: N1008
- 021 Invalid Weight Unit**  
Weight Unit data element should be LG, KG, L or K  
  
Transaction set 309: N1007 not a valid Unit of Measure (UOM)
- 030 Invalid IB Entry Type**  
Segment M11 is for type 04 master in-bond (MIB), but In-bond Entry Type data element contains  
something other than 61, 62, 63, 69 or 70.  
  
Transaction set 309: M1201 – shipment is In-bond but entry type code is something other than 61, 62,  
63, 69 or 70.
- 032 Invalid Inbond Number**  
Segment M12 is for type 3 MIB, but paperless In-bond Number data element contains data that is not  
numeric, spaces, or zero.  
  
Transaction set 353: M1501/M1502: the in-bond number specified does not exist or is invalid.
- 033 Invalid DDPP**  
Port of Arrival, Port of Loading or In-Bond Port of Destination contains a code that does not appear in  
the Schedule D - U.S. CBP Port Codes list.  
  
Transaction set 309/353/358, check:  
Segment P4 – P401 District/Port of Unlading Code is invalid  
Or  
Segment M11 is for type 04 MIB, but the In-Bond Port of Destination is invalid



MOTOR TRANSPORTATION INDUSTRY APPLICATIONS  
CUSTOMS MANIFEST ACCEPTANCE/REJECTION

Version 15 - Updated 2/14/2023

Or

Segment M12 is for type 03/04 MIB, but the M1203 U.S Port of Destination/Intermediate Destination is invalid.

**034 Invalid Foreign Port**

A valid foreign destination port is required for in-bond type 62 and 63 shipments.

Transaction set 309:

M1102 – foreign port of loading code is missing or not in the Schedule K code list.

Or

M1204 – in-bond destination foreign port code is missing or not in the Schedule K code list.

**035 Invalid Dollar Value**

Value data element contains data that is not numeric or 0.

Transaction set 309:

N1006: in-bond shipment value must be greater than 0.

**038 B/L Already on File**

The Bill of Lading sequence Number/shipment control number provided is a number that has already been transmitted within the past 3 years.

Transaction set 309:

M1101/M1112: bill of lading number/shipment control number cannot be reused within a specified period of time if an active bill already exists.

**041 Missing Container Number**

The Container Number data element contains spaces.

Transaction set 309/358:

VID02/VID03/VID14 missing or invalid

Or

No in-bond data found for equipment number and SCAC with status DP.

**042 Invalid Quantity**

Shipment/Bill of Lading Quantity is not numeric or 0.

Transaction set 309:

Segment N10 – N1001 Commodity Piece Count data element contains a quantity that is not numeric or contains spaces.

**046 Invalid Amendment Code**

Amendment Code data element is invalid.

Transaction set 309: M1016 (manifest) or M1306 (shipment)

**047 Missing Description**

Description data element was not transmitted or contains blanks.

Transaction set 309

Segment N10 – N1002 shipment commodity missing.

**050 Invalid Estimated Arrival Date**

Original Estimated Date of Arrival data element contains an arrival date in format other than CCYYMMDD.

Transaction sets 309, 353, 358: P402 estimated arrival date is missing or invalid.

**060 XXXX Bill Rejected XXXX**

Record Identifier B01/Segment M11 was not processed because of an error previously transmitted;  
In EDIFACT:CUSCAR RFF0380C506 1154

Or

MOTOR TRANSPORTATION INDUSTRY APPLICATIONS  
**CUSTOMS MANIFEST ACCEPTANCE/REJECTION**

Version 15 - Updated 2/14/2023

Record Identifier A01/Segment M13 has to be added as  
 It of any error. The error type has been previously transmitted  
 Or  
 Record identifier K01/Segment M13 has to be added as  
 result of any error. The error type has been previously  
 transmitted

- 074 Incorrect Harmonized #**  
 Record Identifier D00/Segment N10 – Harmonized  
 Number Data Element contains data that doesn't appear  
 in Harmonized Schedule File.  
 In ANSI X12: 309 Set N1005: TE/IE shipment and commodity code  
 specified does not exist;  
 in EDIFACT: CUSCAR: CST0730 C246 7361, 1131
- 081 Manifest Transmittal**  
 The posting initiator found in the AMS transaction screen  
 Indicates the manifest transmission was successful
- 098 Not Authorized to Transmit**  
 Record Identifier ACR/Segment BG (ISA) User Code Data Element  
 contains data that indicates there is no user record for district/port  
 site-carrier-port.  
 In ANSI X12: A district/port site record exists but the user is not  
 authorized to transmit  
 EDIFACT: CUSCAR UNH0010 0062
- 131 Entity already arrived**  
 In ANSI X12: 353 Set M1501 code 3:arrival by container/equipment  
 rejected. User attempts to arrive inbond by container/equipment but  
 1 or more inbonds or bills associated with the container are already  
 arrived. User must either unarrive the inbonds or bills and then  
 arrive the container/equipment, or arrive all the inbonds or bills  
 individually.  
 In EDIFACT: CUSREP: DOC0160 C002 1001 code 98, RFF0170  
 C506 1153 code AGP
- 158 FIRMS Code not on File**  
 The provided FIRMS code is invalid or not on file.
- 198 Invalid Manifest Type Code**  
 In ANSI X12: 309/358, 353 set Record Identifier M10 – Manifest  
 Type Code  
 (M1009) is anything other than P,X,Y,T,S,3,H/ 309/358 Set. M1017:  
 any code other than '8','9'; In EDIFACT: CUSCAR (W) BGM  
 DE1001=85 and DE1225=22/ (P) BGM DE1001=87 and  
 DE1225=2/(Y)BGM DE1001=85 and DE1225=4/ (3)BGM1001=85  
 and DE1225=3/CUSREP BGM DE1001=336 and DE1225=3
- 204 No Man Unit Code for BL**  
 Record Identifier D01/N10 – Manifest Unit Code is other than codes  
 in note for this element; in EDIFACT: CUSCAR PAC0650 C202  
 7065
- 209 BL not on File or Deleted**  
 In ANSI X12: 358 Set: Record Identifier MBL/MBL – Bill  
 of Lading number not in database or is in deleted status  
 309 Set M1301/M1304: shipment control number  
 specified doesn't exist;  
 in EDIFACT: CUSREP RFF0170 C506 1154
- 215 Invalid Est Arr Time**

MOTOR TRANSPORTATION INDUSTRY APPLICATIONS  
**CUSTOMS MANIFEST ACCEPTANCE/REJECTION**

Version 15 - Updated 2/14/2023

Record identifier P01/P4 in 358 set (consist): the estimated arrival time is in a different format from the HHMM 24 format, or 0's or blanks.

In ANSI X12: 309, 353, 358 sets P405: time is missing or invalid

In EDIFACT: CUSCAR: DTM0030 C507 2380/2379

CUSREP: DTM0030 C507 2380/2379

**242**

**C4 Code not Valid**

Record Identifier D01/Segment N10: The Customs bar code number (C4) is invalid by Line Release

309 Set N1009: C4 code specified for BRASS shipment does not exist or is invalid;

In EDIFACT: CUSCAR CST 0730 C246 7361

**255**

**Inbond Exists for this Bill**

A carrier-issued or QP filer-submitted initial in-bond is already active for this bill.

**324**

**Invalid Pedimento Number**

The pedimento number in N9/B04 reference number does not have the valid number.

In ANSI X12: 309 Set N901/N902. M1201 is type '63' CBP port of in-bond destination is a Mexican border port and the pedimento number is missing or invalid.

In EDIFACT: CUSCAR DOC0365 C002 1001 C503 1004

**377**

**FAST Driver Inv for Intransit**

309/358 DMG, N3, REF: Invalid FAST driver for intransits.

Mandatory information not filed for crew.

**378**

**Inv Intransit Man Filer**

309/358 M1001: Carrier not a participant in intransit program

**379**

**Inv Ship Data**

309 M1109, M1201: All shipments on an intransit manifest must be entry code 70 in M1201.

**401**

**Inv Conv ACE ID**

In ANSI X12: 309/358 Set VEH21/VEH22: ACE ID specified does not exist or is invalid per carrier account;

In EDIFACT: CUSCAR TDT0170 C222 8212/CUSREP DT0370 C222 1131

There may also be an issue with the Carrier's ACE account – check that the SCAC is Active and has not expired.

**402**

**Inv Lic Plate State for Trip**

In ANSI X12: 309/358 Set VEH10/VID14: state/province doesn't exist;

in EDIFACT: CUSCAR RFF0326 C506 1153, TDT0170 C222 8212/CUSREP LOC0516 C516 1153, TDT0370 C222 8212

**403**

**Missing Lic Plate Country**

In ANSI X12: 309/358 Set VEH17/VID16: country is other than US, MX, CA and is missing;

In EDIFACT: CUSCAR LOC0327 C517 3225/ CUSREP LOC0518 C517 3225, TDT0370 C222 453

**404**

**Inv Lic Plat Country for Trip**

In ANSI X12: 309/358 Set VEH17/VID16: country specified doesn't exist or is invalid;

In EDIFACT: CUSCAR LOC0327 C517 3225, TDT017 C222 8453/ CUSREP LOC0516 C17 3225, TDT0370 C222 8453

MOTOR TRANSPORTATION INDUSTRY APPLICATIONS  
CUSTOMS MANIFEST ACCEPTANCE/REJECTION

Version 15 - Updated 2/14/2023

- 405 Invalid Conv Code**  
In ANSI X12: 309/358 Set. VEH 21/VEH22: Conveyance ID specified doesn't exist or is invalid per carrier account; in EDIFACT: CUSCAR TDT0170 C2228212/  
CUSREP TDT0370 C222 8212
- 407 Ins Info Incomplete**  
In ANSI X12: 309/358 sets CII01, CII02, CII03, CII05 Insurance information not complete for trip  
In EDIFACT: CUSCAR: FTX 0150 C108 4440 or CUSREP: MOA 0220 C516 5004, FII 0230 C088 3432, RFF 0250 C506 1154, DTM 0260 C507 2380.
- 408 Ins Info not Maintained**  
In ANSI X12: 309/358 sets CII01, CII02, CII03, CII05: insurance information not maintained for trip.  
In EDIFACT: CUSCAR: FTX 0150 C108 4440 or CUSREP: MOA 0220 C516 5004, FII 0230 C088 3432, RFF0250 C506 1154, DTM 0260 C507 2380.
- 409 No Person in Charge**  
In ANSI X12: 309/358 Set NM101: no crewmember is listed as 'EJ';  
In EDIFACT: PAXLST NAD 160 3035: no crewmember is listed as 'VW'
- 410 No Driver CDL/Lic for Trip**  
In ANSI X12: 309/358 Set REF01: No crewmember is listed as having CDL or driver's license;  
In EDIFACT: PAXLST EMP0240 9003, C950 98007
- 411 Crew ACE ID not for Carr**  
In ANSI X12: 309/358 Set NM108: ACE ID specified for crewmember is not pre-registered in carrier's account;  
In EDIFACT: CUSCAR NAD0100 C082 3039
- 412 No Gender Code**  
In ANSI X12: 309/358 Set DMG03: gender code is missing or other than 'M'/'F';  
In EDIFACT: PAXLST ATT0170 C956 9019
- 413 No Hazmat Endorse for Crew**  
In ANSI X12: 309 Set Hazmat code, insurance information present, Hazmat endorsement missing;  
In EDIFACT: PAXLST EMP0240 C950 9007
- 415 No Hazmat Contact**  
In ANSI X12: 309 Set H105. Hazmat contact missing;  
In EDIFACT: CUSCAR FTX0670 C108 4440, DGS0710 PAXLST EMP0240
- 416 Int Error – Take no Action**  
Various segments: an internal error has occurred in processing
- 417 Trip Number Required**  
In ANSI X12: 309, 353, 358 sets M1005 trip number missing or invalid.  
In EDIFACT: CUSCAR: BGM0020 C106 1004 ;  
CUSREP BGM0020 C106 1004
- 418 Duplicate Trip Number**

MOTOR TRANSPORTATION INDUSTRY APPLICATIONS  
**CUSTOMS MANIFEST ACCEPTANCE/REJECTION**

Version 15 - Updated 2/14/2023

In ANSI X12: 309/358 Set M1006: Trip number reused within a specified time period: 1 year for preferred, 1 day for standard;  
 In EDIFACT: CUSCAR BGM0020 C106 1004/CUSREP BGM0020 C106 1004

- 419 Invalid SCAC on Trip Number**  
 Invalid NMFTA SCAC code  
 In ANSI X12: 309/358 sets M1001: SCAC not valid or doesn't Exist;  
 In EDIFACT: CUSCAR NAD0100 C082 3039/CUSREP NAD0290 C082 3039
- 420 No Transp on Conv for Trip**  
 In ANSI X12: 309/358 Set VEH24: Preferred manifest, registered conveyance no transponder in conveyance profile;  
 In EDIFACT: CUSCAR TDT0170 C222 8212/ CUSREP TDT0370 C222 8212  
 FUTURE USE
- 422 Inv Combination for Trip**  
 In ANSI X12: 309 set. N3,N4: combination of state/province and country is not correct for shipment and party type.  
 In EDIFACT: CUSCAR NAD0540 C819 3229 3207
- 424 Inv SCAC on Shipment**  
 Invalid NMFTA SCAC code  
 In ANSI X12: 309 Set M1301/10,M1112/13: SCAC not valid or doesn't exist;  
 In EDIFACT: CUSCAR DOC0365 C002 1001, RFF0380 C506 1153
- 425 No Shipment Rel Type Filed**  
 In ANSI X12: 309 Set M1109: preferred manifest – release type not specified  
 FUTURE USE
- 427 Inv Amend Code for Trip**  
 In ANSI X12: 309/358 Set M1016: amendment code doesn't exist for trip use;  
 In EDIFACT: CUSCAR RFF0070 C506 1154/ CUSREP RFF0010 C506 1154
- 428 Inv UN Danger Goods Code**  
 In ANSI X12: 309 Set H101: UN code specified is incorrect or doesn't exist;  
 In EDIFACT: CUSCAR FTX0670 4451, C108 4440
- 429 Inv Shipment Party Type**  
 In ANSI X12: 309 Set N101: party type specified not in list;  
 in EDIFACT: CUSCAR NAD0540 3035
- 430 Inv Filer Code for Shipment**  
 In ANSI X12: 309 Set N104: broker filer code specified doesn't exist or is incorrect;  
 In EDIFACT: CUSCAR NAD0540 C082 3039
- 432 Trip Number does not Exist**  
 In ANSI X12: 309/358 Set M1005: update of manifest – trip specified doesn't exist; in EDIFACT: CUSCAR BGM0020 C106 1004/CUSREP BGM0020 C106 1004
- 433 Inv Equip Identifier for Trip**

MOTOR TRANSPORTATION INDUSTRY APPLICATIONS  
**CUSTOMS MANIFEST ACCEPTANCE/REJECTION**

Version 15 - Updated 2/14/2023

In ANSI X12: 309/358 Set VID02/VID03,VID14/VID15/VID16:  
 either equipment number or license plate required for trip;  
 In EDIFACT: CUSCAR EQD0220 8053/ CUSREP EQD0500 8053

- 434 Inv Party Type,ID and Comb**  
 In ANSI X12: 309 Set N103: qualifier not specified in this element;  
 In EDIFACT: CUSCAR NAD0540 C082 3039,1131
- 435 Amend Code not Filed**  
 In ANSI X12: 309 Set M1306: amendment code missing after  
 'manifest complete' message;  
 In EDIFACT: CUSCAR RFF0510 C506 1154
- 436 Inv DUNS Number**  
 In ANSI X12: 309 Set N103/N104: Duns number specified doesn't  
 exist or is invalid;  
 In EDIFACT: CUSCAR NAD0540 C082 3039, 1131
- 439 Inv Trip Party ACE ID**  
 In ANSI X12: 309/358 Set NM108/NM109:party specified does not  
 exist or is invalid per carrier account records;  
 In EDIFACT: CUSCAR NAD0100 C082 3039/  
 CUSREP NAD0290 C082 3039
- 440 Inv Shipment Party ACE ID**  
 In ANSI X12: 309 Set N103/N104: preferred shipment, ACE ID  
 doesn't exist or is invalid per carrier account records;  
 In EDIFACT: CUSCAR NAD0540 C082 3039
- 441 Conv Lic Plate Data Missing**  
 In ANSI X12: 309/358 Set VEH09: license plate data missing; in  
 EDIFACT: CUSCAR TDT0170 C222 8212/  
 CUSREP TDT0370 C222 8212
- 443 Shipment not found for IB**  
 In ANSI X12: 353 set M1501/M1502 the in-bond number specified  
 has no associated shipments;  
 In EDIFACT: CUSREP DOC0365 C503 1004
- 446 Brd Qty Grtr than Shp Qty**  
 In ANSI X12: 309 Set N1001,358 Set MBL06: total of boarded  
 quantities in split shipment is greater than original manifested  
 quantity for bill;  
 In EDIFACT: CUSCAR CNT0390 C270 6069
- 447 Inv Split of Shipment**  
 In ANSI X12: 309 Set M1109,358 Set MBL06: carrier attempts to  
 create a split shipment but shipment release type will not allow  
 splits;  
 In EDIFACT: CUSCAR CNT0390 C270 6069
- 448 Inv Equipment Type**  
 In ANSI X12: 309 Set VID01: type specified doesn't exist or is  
 invalid;  
 In EDIFACT: CUSCAR EQD0220 8053
- 449 Inv Lic Plate Comb for Shp**  
 In ANSI X12: 309 Set VID18/16: combination of state/province and  
 country is not correct;  
 In EDIFACT: CUSCAR TDT0170 C222 8453, LOC327 C517 3225,  
 LOC0180 C517 1131, EQD0220 , RFF0326
- 452 Inv IIT Code for Trip**

MOTOR TRANSPORTATION INDUSTRY APPLICATIONS  
**CUSTOMS MANIFEST ACCEPTANCE/REJECTION**

Version 15 - Updated 2/14/2023

- In ANSI X12: 358 Set VEH23/VID18: IIT code doesn't exist or is invalid;  
 In EDIFACT: CUSREP RFF0100 C506 1154, RFF0516 C506 1154
- 454 Inv Party ST for Trip**  
 In ANSI X12: 309/358 Set N3,N4: address specified for crew is not US address;  
 In EDIFACT: PAXLST NAD0160 C819 3229
- 455 Inv Party ZIP for Trip**  
 In ANSI X12: 309/358 Set N403: ZIP code specified for crew is not US ZIP code; in EDIFACT PAXLST NAD0160 3251
- 456 Inv Travel Doc type on Trip**  
 In ANSI X12: 309/358 Set REF01: code specified for crew travel document does not exist or is invalid; in EDIFACT: PAXLST DOC0280 C002 1001
- 457 Inv Travel Doc St/Ctry Com**  
 In ANSI X12: 309/358 Set REF03/05: State/Province code specified does not match country code other than US, MX, CA; In EDIFACT: PAXLST LOC0320 3227
- 458 Inv Conv Type for Trip**  
 In ANSI X12: 309/358 Set VEH20: conveyance type code specified does not exist or is invalid;  
 In EDIFACT: CUSCAR TDT0170 8178/ CUSREP TDT0370 8178
- 462 Req Conveyance Info Missing**  
 In ANSI X12: 309/358 sets VEH segment: VIN number/transponder number missing  
 In EDIFACT: CUSCAR: TD0170  
 CUSREP TDT0370
- 464 EQ Lic Plate/Number Missing**  
 In ANSI X12: 309/358 sets: VID14, VID16, VID18, VID02, VID03  
 In EDIFACT: RFF0516 C506 1153-1154
- 465 Comp Crew Info not Filed**  
 In ANSI X12: 358 Set NM1,DMGREF,N3,N4: complete crew information missing;  
 In EDIFACT: PAXLST DOC, LOC,ATT, NAT, NAD
- 466 Missing Complete Crew Info**  
 In ANSI X12: 309/358 sets REF segment: complete crew Information not filed for trip  
 In EDIFACT: CUSCAR: NAD100  
 CUSREP: PAXLST: DOC0280
- 467 No Travel Doc for Crew**  
 In ANSI X12: 309/358 sets REF05: country code Specified does not exist or is invalid  
 In EDIFACT: PAXLST LOC0320 C17 3225
- 468 Inv Travel Doc Ctry**  
 In ANSI X12: 309/358 Set REF05: country code specified does not exist or is invalid;  
 In EDIFACT: PAXLST LOC0320 C17 3225
- 469 Equip Lic Plate Missing**  
 In ANSI X12: 358 Set VID14: equipment license plate is missing or invalid;  
 In EDIFACT: CUSREP RFF0516 C506 1154

MOTOR TRANSPORTATION INDUSTRY APPLICATIONS  
**CUSTOMS MANIFEST ACCEPTANCE/REJECTION**

Version 15 - Updated 2/14/2023

- 470**            **Inv Ctry of Orig for Shp**  
 In ANSI X12: 309 Set N1011: Sec 321 entry, country code specified does not exist or is invalid;  
 In EDIFACT CUSCAR LOC0740 C517 3225
- 472**            **For Port must be Sch K**  
 In ANSI X12: 309 Set M1102: if the shipment is preferred the estimated port of departure is anything other than Schedule K code in EDIFACT: LOC410 C517 1131  
 FUTURE USE
- 473**            **Imp not CTPAT for Pref**  
 In ANSI X12: 309 Set N101-02: preferred shipment and importer not CTPAT approved as per account records;  
 In EDIFACT: CUSCAR NAD0540 C082 3039, NAD0540 3035  
 FUTURE USE
- 474**            **Inv Equip IIT Code for Trip**  
 In ANSI X12: 358 Set VID18: IIT code is anything other than C,I, A, B;  
 In EDIFACT CUSREP RFF0516 C506 1154
- 475**            **Man Com Dt not Allowed**  
 In ANSI X12: 309/358 Set P402: create date is more than 90 days in advance of estimated arrival date; in EDIFACT CUSCAR DTM0030 C507 2380/CUSREP DTM0030 C507 2005
- 477**            **Brd Qty Sum Grtr Shp Qty**  
 In ANSI X12: 358 Set MBL06/309 Set N1001: Sum of all boarded quantities from all trips is greater than total shipment quantity;  
 In EDIFACT: CUSCAR PAC0650 C202 7065/ CUSREP CNT0390 C270 6069
- 478**            **Inv Seal # Duplicate for Trip**  
 In ANSI X12: 358 Set M7:same seal numbers specified for multiple equipment; in EDIFACT: CUSREP SEL0513 9308
- 480**            **No FDA Conf in TE**  
 In ANSI X12: 309 Set M1212: FDA confirmation code is missing or is invalid;  
 In EDIFACT: CUSCAR GEI0420 C012 7365
- 481**            **Inv IIT Code for Ship**  
 In ANSI X12: 309 Set VID18: IIT code is anything other than C,I, A, B;  
 In EDIFACT: CUSCAR: RFF0326 C506 1154
- 482**            **Mismatch of Equip Data**  
 In ANSI X12: 309/358 Set VID02,0314,15,16: preliminary 309 bills translated with an equipment number that is not duplicated in the 358 consist;  
 In EDIFACT: CUSCAR EQD0220 C237 8260, RFF0326 C506 1154, LOC0327 C517 3225/ CUSREP EQD0500 C237 8260, RFF0516 C506 1144, LOC0327 C517 3225
- 483**            **Conv/Equip ACE ID not for Carr**  
 In ANSI X12: 309/358 Set VEH21, VID17: the conveyance/equipment ACE ID specified is not registered to the carrier;



MOTOR TRANSPORTATION INDUSTRY APPLICATIONS  
**CUSTOMS MANIFEST ACCEPTANCE/REJECTION**

Version 15 - Updated 2/14/2023

In EDIFACT: CUSCAR TDT0170 C222 8212, EQD0220 C237  
 8260/ CUSREP TDT0370 C222 8212, EQD0500 C237 8260

- 485 Inv Amount for Sec 321**  
 In ANSI X12: 309 Set M1109/N1006: value of commodity is greater than \$200;  
 In EDIFACT: CUSCAR MOA0690 C516 5004
- 486 Inv FAST Number**  
 In ANSI X12: 309 Set N103/04: FAST number specified is registered in FAST system to different carrier; in  
 EDIFACT: CUSCAR NAD0540 C082 3039
- 487 Missing Req Ship Party Data**  
 In ANSI X12: 309 Set N101/N102: missing entity identifier code and/or name;  
 In EDIFACT: CUSCAR NAD0540 3035, NAD0540 C080 3036
- 488 No empty Shipments in Pref**  
 In ANSI X12309 Set: M1009/M11: a shipment designated as 'preferred' missing shipment records, cannot be empty  
 FUTURE USE
- 489 Inv Link of Man Type for Trip**  
 In ANSI X12: 358 Set M1009: carrier attached a preferred bill to a standard manifest  
 FUTURE USE
- 490 Inv Travel Doc Number**  
 In ANSI X12: 309/358 sets REF02  
 Proximity card, travel document number, FAST ID not in account or duplicate.  
 In EDIFACT: PAXLST DOC0280 C002 1001
- 491 Ship Data Mixed with Rel Types**  
 In ANSI X12: 309 set M1109, M1201  
 2 different types of releases in same shipment: BRASS, inbond  
 In EDIFACT: CUSCAR CST0730 C246 7361
- 492 Shipment on Another Manifest**  
 In ANSI X12: 358 set MBL01, MBL02  
 Shipment data is part of another manifest and linking is not allowed  
 In EDIFACT: CUSCAR RFF0380 C506 1153, CNT0390 C270 6069
- 494 Inv Format for Shipment**  
 In ANSI X12: 309 set M11, M13  
 Format isn't alphanumeric without spaces for shipment  
 In EDIFACT: CUSCAR RFF0380 C506 1153
- 495 INV Format for Manifest**  
 In ANSI X12: 309/358/353 sets M10, VEH, NM1, DMG, REF  
 Format isn't alphanumeric without spaces in between  
 In EDIFACT: BGM TDT
- 496 Duplicate License Plate**  
 In ANSI X12: 309/358 sets VEH09,VID14  
 Duplicate license plate for trip or shipment  
 In EDIFACT: CUSCAR TDT 0170 C222 8453, LOC327 C517 3225, LOC0180 C517 1131, EQD0220, RFF0326, LOC0327
- 497 Duplicate Equipment**

MOTOR TRANSPORTATION INDUSTRY APPLICATIONS  
**CUSTOMS MANIFEST ACCEPTANCE/REJECTION**

Version 15 - Updated 2/14/2023

In ANSI X12: 398,358 sets VID02,03

Duplicate equipment for trip or shipment: equipment number is repeated on same shipment or trip

In EDIFACT: CUSCAR TDT 0170 C222 8453, LOC327 C517 3225, LOC0180 c517 1131

- 498 Duplicate Trip Party**  
 In ANSI X12: 309 set N101  
 Duplicate trip party for trip: 2 parties with the same details.  
 In EDIFACT: CUSCAR NAD0100 C0801/C058
- 499 Missing Mand Crew Info**  
 In ANSI X12: 309/358 NM1, DMG, N3, REF  
 Mandatory crew information is not filed for crew: last name, first name, DOB.  
 In EDIFACT: PAXLST NAD,ATT,DTM, EMP,NAT,DOC
- 500 Invalid Filing Status**  
 In ANSI X12: 309/358 sets M1306  
 Invalid filing status to update the trip: attempting to file amendment codes on preliminary bills.  
 In EDIFACT: CUSCAR RFF0510 C506 1154,CUSREP RFF0100 C506 1154
- 501 Inv License Plate Number**  
 In ANSI X12: 309/358 sets VEH09,VID14  
 Number exceeds 10 positions.  
 In EDIFACT: CUSCAR TDT0170 C222 8453, LOC327 C517 3225, LOC0180 C517 1131
- 502 Inv DOT Number**  
 In ANSI X12: 309/358 sets VEH25  
 Number exceeds 8 positions  
 In EDIFACT: CUSCAR TDT0170 C222 1131, CUSREP TDT0370 C222 8212
- 503 Expected Port cant be Changed**  
 In ANSI X12: 309/358/353 sets P401  
 Expected port of arrival changed to anything other than actual port of arrival after arrival of conveyance  
 In EDIFACT: CUSCAR LOC0040 C517 3225, CUSREP LOC0130 C517 3225
- 504 Pref Manifest not Allowed**  
 In ANSI X12: 309,358 sets M1009/M1017  
 Preferred manifest not allowed for carrier  
 Carrier not permitted for FAST  
 In EDIFACT: CUSCAR BGM0020 1225
- 505 No ACE ID or CDL Provided**  
 In ANSI X12: 309/358 NM108-09/REF01-02  
 No ACE ID or CDL provided for at least 1 crewmember  
 In EDIFACT: PAXLST DOC0280 C002 1001, DOC0280 C503 1004
- 507 Carrier not C-TPAT**  
 In ANSI X12:  
 Carrier registered for trip not C-TPAT in account
- 508 Required Trip Info Missing**  
 In ANSI X12: 309/358 sets M10,P4  
 Required trip information missing for trip: date,time  
 In EDIFACT: CUSCAR,CUSREP BGM, LOC DTM

MOTOR TRANSPORTATION INDUSTRY APPLICATIONS  
**CUSTOMS MANIFEST ACCEPTANCE/REJECTION**

Version 15 - Updated 2/14/2023

- 509 Manifest Rejected**  
 In ANSI X12: 309/358 sets M10, P4, VEH, NM1, DMG, REF, N3,N4, M11, N1, N3, N4, VID, N10  
 Required information for complete manifest missing: trip, crew, conveyance, equipment, shipments.  
 In EDIFACT: CUSCAR/CUSREP BGM, LOC, DTM, QTY, RFF, NASD, TDT,EQD, CNI
- 510 Req Ship Party not Given**  
 In ANSI X12: 309 set N101, N102: required shipment Party data not provided for the shipment  
 In EDIFACT: CUSCAR: NAD0540 NAD0100, NAD0590 CUSREP: NAD0290
- 511 Man Returned to Preliminary**  
 In ANSI X12: 309 set M1009: complete manifest code 'W' In M1009 has shipments rejected: need bill corrected, retransmitted, and 353 set to confirm manifest is complete  
 In EDIFACT: CUSCAR: BGM, DTM
- 512 Inv Est Date of US Exit**  
 In ANSI X12: 309 set M1213: estimated date of Departure for in-bond shipment where M1201 is 62 or 63 is invalid or blank  
 In EDIFACT: CUSCAR: DTM0480 C507 2380
- 513 Mismatch of Codes at Trip**  
 In ANSI X12: 309 M1009, M1005: M1009 code is 'W' for Complete manifest, but M1005 has 'system' not trip Number  
 In EDIFACT: CUSCAR: BGM0020 C1006 1004
- 514 Errors on more than 100 SCN**  
 This error message is returned after there have been errors in over 100 shipments. It is a warning message intended for the sender to check all of his shipments.  
 ACE stops processing errors after 100 shipments Normally this occurs when one or more errors are present in each shipment. The sender is highly encouraged to look at all shipments for similar errors.
- 515 Man Arrivd Cant be Cancelld**  
 In ANSI X12: 309/358 sets M1009: sender attempts to delete a manifest after conveyance has been arrived at the first US port.  
 In EDIFACT: CUSCAR: BGM0020 C106 1225 CUSREP: BGM0020 C106 1225
- 517 Trans ID not in ACE as SCAC**  
 Transmitter ID not found in ACE as a SCAC  
 In ANSI X12: Header/Trailer records: ISA segment: the transmitter ID in ISA06, either SCAC or mutually defined ID, is not configured in ACE.  
 In EDIFACT: UNB S002 0004,0007
- 518 Prep ID nor in ACE as SCAC**  
 Preparer ID not found in ACE as SCAC or filer  
 In ANSI X12: Header/trailer records: GS02/GS03:preparer ID not configured in ACE  
 In EDIFACT: UNG S006 0040,0007/ UNG S007 0044,0007

MOTOR TRANSPORTATION INDUSTRY APPLICATIONS  
**CUSTOMS MANIFEST ACCEPTANCE/REJECTION**

Version 15 - Updated 2/14/2023

- 519 Trans ID has no EDI Profile**  
 Transmitter ID does not have an EDI profile for this message type/format  
 In ANSI X12: Header/trailer records: GS02/GS03: A profile has been set up in ACE for the preparer but the transmitter's account does not reference the preparer.  
 In EDIFACT: UNG S006 0040, 0007/UNG S007 0044,0007
- 520 No Trans/Prep Relationship**  
 Transmitter and Preparer relationship not found  
 In ANSI X12: Header/trailer records: GS02/GS03: even though a proper EDI profile has been set up for both transmitter and preparer, transmitter is not authorized to send  
 In EDIFACT : UNG S006 0040, 0007/ UNG S007 0044, 0007
- 521 Trans also Preparer**  
 Transmitter is also indicated as the preparer on this IDOC, but transmitter EDI profile does not agree.  
 In ANSI X12: Header/trailer records: ISA06/ISA08 and GS02/GS03: self preparer flag not set in transmitter's profile  
 In EDIFACT: UNB S002 0004,0007/ UNB S003 0010,0007;  
 UNG S006 0040, 0007; UNG S006 0044, 0007
- 522 Msg Typ not allowed for Prod**  
 Transmitter EDI profile does not allow this message type/format to be sent in production yet  
 In ANSI X12: Header/trailer records: ISA06/ISA08: transmitter sends in manifest before authorized startup date in production  
 In EDIFACT: UNB S002 0004,007/UNB S003 0010,0007
- 523 US Export Date over 45 Days**  
 Shipment claiming release as free astray or under Headnote1 of the Tariff Act has been out of the US for more than 45 days.  
 In ANSI X12: 309 set: M1127 date is over 45 days from date of expected reimportation into US.  
 In EDIFACT: DTM 0480 C5007 2379
- 524 Carr/Customs Custody eq N**  
 Shipment claiming release as free astray or under Headnote1 of the Tariff Act has been out of foreign Customs or carrier's custody while out of the US.  
 In ANSI X12 : 309 set: M1128 code 'N' is supplied.  
 In EDIFACT: GEI 0420 C012 765 code 136 is missing.
- 525 Incorrect SCAC/TRIP**  
 SCAC/trip number in M10 of 353 set, BGM of CUSCAR doesn't match the SCAC/trip number of the original M10 of 309, BGM of CUSCAR.  
 In ANSI X12: 353 set M1001, M1005  
 In EDIFACT: CUSCAR BGM0020 C106 1004
- 526 Seal Numbers in Delink**  
 Seal numbers are provided in a delink transaction in 358 set, CUSREP.  
 In ANSI X12: 358 set M7 segment is provided after VEH or VID segments  
 In EDIFACT: RFF0100 C506 1153/1154, SEL0513 9308
- 527 Inv Address in Profile**  
 Carrier has an invalid address in ACE profile.

MOTOR TRANSPORTATION INDUSTRY APPLICATIONS  
**CUSTOMS MANIFEST ACCEPTANCE/REJECTION**

Version 15 - Updated 2/14/2023

- 528 Invalid MOT**  
 Carrier attempt to transmit using a Method Of Transportation .  
 Other than 'J' in the M10 segment of 309/358/353 sets or '03' in  
 TDT in CUSCAR and CUSREP  
 In ANSI X12: 309/358/353 M1002 anything other than 'J'  
 In EDIFACT: CUSCAR/CUSREP TDT0170 C220 8066/TDT0370  
 C220 8067 anything other than '03'
- 529 No Ent Type Change for Inb**  
 Carrier attempts to change entry type for inbond shipment  
 In ANSI X12 309 set M13/M1201: changing codes '61','62','63'  
 In EDIFACT: CUSCAR DOC0365 C002 1001
- 530 No Cn Arr if Mult Dest IB**  
 Carrier attempts to arrive inbond by container/equipment in one  
 destination port but inbond-bills associated with the  
 container/equipment are for various destination ports. To arrive by  
 container equipment all inbond-bills must be for the same  
 destination port in which the container/equipment is arrived.  
 In ANSI X12: 353 set M1501 code 3, M1502 container/equipment  
 number In EDIFACT: CUSREP DOC0160 C002 1001 code  
 98,RFF0170 C506 1153 code AGP for container/equipment arrival  
 Various inbond destinations provided in CUSCAR LOC0410 C517  
 3225 for inbonds in CUSCAR DOC0365 C503
- 531 No Cn Exp If Mult Dest IB**  
 Carrier attempts to export inbond by container/equipment in one  
 destination port but inbond-bills associated with the  
 container/equipment are for various destination ports. To arrive by  
 container equipment all inbond-bills must be for the same  
 destination port in which the container/equipment is arrived.  
 In ANSI X12: 353 set M1501 code7, M1502 container/equipment  
 number. In EDIFACT: CUSREP DOC0160 C002 1001 code  
 833,RFF0170 C056 1153 code AGP for container/equipment export  
 Various inbond destinations provided in CUSCAR LOC0410 C517  
 3225 for inbonds in CUSCAR DOC0365 C503
- 532 Inbond Export Rej**  
 Carrier attempts to export inbond by inbond number, bill of lading  
 number, or container-equipment number but (1) the inbond has not  
 been arrived at the destination inbond port or (2) the inbond has  
 been arrived but a hold exists on a bill associated with the inbond  
 .(3) the inbond has already been exported  
 ANSI X12: 353 set M1501 codes 5, 6, 7 M1502 inbond number,  
 BOL number, container –equipment number  
 In EDIFACT: CUSREP DOC0160 C002 1001 code 833, RFF0170  
 C056 1153 codes AAM for waybill number, AGP for company  
 issued equipment ID, or IB for inbond number
- 533 Inbond Cancel Rej**  
 Carrier attempts to cancel arrival/export inbond by inbond number,  
 bill of lading number, or container-equipment number but (1) the  
 inbond has not been arrived at the destination inbond port or (2) the  
 inbond has been arrived but a hold exists on a bill associated with  
 the inbond .(3) the inbond has already been cancelled  
 ANSI X12: 353 set M1501 codes F,G,H,I,J,K M1502 inbond  
 number, BOL number, container –equipment number  
 In EDIFACT: CUSREP BGM0020 1225 code 1, DOC0160 C002  
 1001 code 98, 833, RFF0170 C056 1153 codes AAM for waybill  
 number, AGP for company issued equipment ID, or IB for inbond  
 number
- 534 MAN OR ACCNT MISS CIT CODE**

MOTOR TRANSPORTATION INDUSTRY APPLICATIONS  
**CUSTOMS MANIFEST ACCEPTANCE/REJECTION**

Version 15 - Updated 2/14/2023

One of two circumstances has occurred. A driver's citizenship has not been reported in the manifest for a "one time" driver. In this case the manifest should be re-submitted with citizenship data. Or, the error has been generated because citizenship is not recorded in the driver's ACE account. This will occur even if citizenship is sent with the manifest but it does not exist in the driver's account. If the driver exists in ACE account the driver's account must be updated either via the ACE Portal or an EDI MEDPID message. In ANSI X12 309 set DMG 06/07: citizenship code and country code are missing.  
 In EDIFACT PAXLST MAT0250 3493 C042 3293: citizenship code and country code are missing. The driver's ACE account is missing citizenship and country code (Active June 2009)

**535**

**MAN OR ACCNT MISS WHTI DOCS**

One of two circumstances has occurred. A valid Western Hemisphere Travel Initiate (WHTI) document has not been reported in the manifest for a "one time" driver. In this case the manifest should be re-submitted with a valid WHTI travel document. Or, the error has been generated because the driver's ACE account does not contain a valid WHTI document. This will occur even if a WHTI document is sent with the manifest but it does not exist in the driver's account. If the driver exists in ACE account data, the driver's account must be updated either via the ACE Portal or an EDI MEDPID message. In ANSI X12 309 set REF01/02: document code and document cited are not WHTI certified.  
 In EDIFACT PAXLST DOC0280 C002 1001 document code and document cited are not WHTI certified. The driver's ACE account document codes and documents that are not WHTI certified (Active June 2009)

**537**

**INVALID EVENT TIME**

The time submitted is either missing or invalid.  
 In ANSI X.12: 353 set M1506

**538**

**INVALID EVENT DATE**

The date submitted is either missing or invalid.  
 In ANSI X.12: 353 set M1503

**542**

**REF INFO DID NOT EXIST**

The reference qualifier submitted is either missing or invalid.  
 In ANSI X.12: 353 set M1501

**544**

**INV FOREIGN PORT QUALIFIER**

In ANSI X.12: 353 set M1125