

# Aluminum Extrusions

## September 2012



U.S. Customs and  
Border Protection

The material in this presentation is provided for guidance and general information purposes only. Reliance on this information alone may not be considered reasonable care.

Because many complicated factors can be involved in Customs issues, an importer may wish to obtain a ruling under the Regulations of U.S. Customs and Border Protection, 19 C.F.R. Part 177, or may wish to obtain advice from an expert who specializes in Customs matters, for example, a licensed Customs Broker, attorney or consultant.





# U.S. Customs and Border Protection

## Our Mission

We are the guardians of our Nation's borders.

We are America's frontline.

We safeguard the American homeland at and beyond our borders.

We protect the American public against terrorists and the instruments of terror.

We steadfastly enforce the laws of the United States while fostering our nation's economic security through lawful international trade and travel.

We serve the American public with vigilance, integrity and professionalism.



# Aluminum Extrusion Scope

AD/CVD Cases

A-570-967

C-570-968

Country of Origin: CHINA



- Be advised, CBP does not make any scope determinations interpreting the scope of the orders of Antidumping/Countervailing Duty (AD/CVD) cases. Such determinations are always rendered by the Department of Commerce (DOC).

In an effort to clarify the complex scopes of AD/CVD cases A-570-967 and C-570-968, CBP has provided examples of products that are determined to be within or outside of the plain language of the scope. If you have any questions about whether your product is covered by the scope of an order, you may apply for a scope ruling from DOC by consulting

**[HTTP://IA.ITA.DOC.GOV](http://IA.ITA.DOC.GOV)**



# EXTRUSION PROCESS

- **Definition: Conversion of an ingot or billet into lengths of uniform cross section by forcing metal to flow plastically through a die orifice.( Metals Handbook by ASM Int.)**
- **Hot Aluminum forced through dies to create a length of cross section.**



# THE EXTRUSION PROCESS

Examples of dies

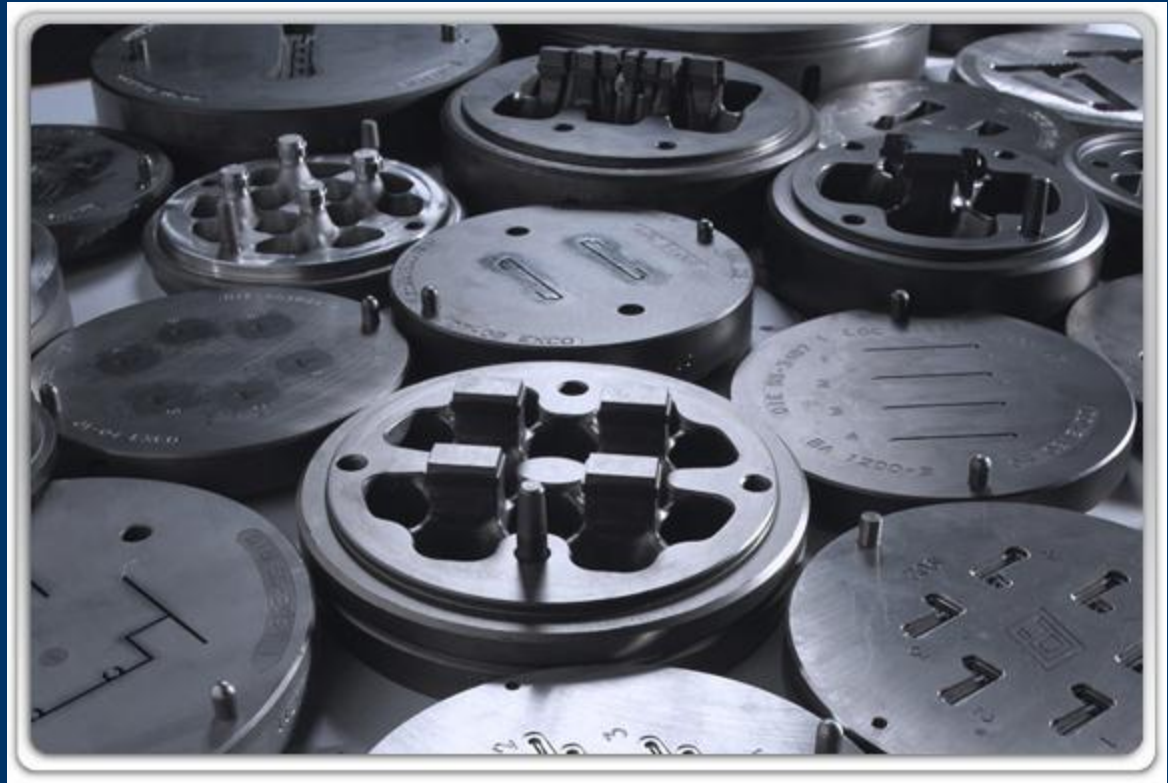

U.S. Customs and  
Border Protection

# ALUMINUM ALLOYS

- Chapter 76 HTSUS; Subheading Note 1(a): Aluminum, ***not alloyed*** – Metal containing by weight at least 99% of aluminum, provided that the content by weight of any other element does not exceed the limit specified in the following table:





# ALUMINUM ALLOYS (cont.)

| Element   | Limiting content % by weight  |
|---|---|
| <b>Fe + Si</b><br><br><b>Other elmnts.(1) each</b>                  | <b>1</b><br><br><b>0.1(2)</b>   |
| <b>(1) Other elements are, for example: Cr, Cu, Mg, Mn, Ni, Zn.</b> | <b>(2) Copper is permitted in a proportion greater than 0.1% but not more than 0.2%, provided that neither chromium nor manganese content exceeds 0.05%</b> |



# ALUMINUM ALLOYS (cont.)

- (b) Aluminum alloys – Metallic substances in which aluminum predominates by weight over each of the other elements, provided that: (i) content by weight of at least one of the other elements or of iron plus silicon taken together is greater than the limit specified in the foregoing table; or
- (ii) total content by weight of such other elements exceeds 1%.



# ALLOYS (cont.)

- **Alloys in the scope explained by DOC**
  
- **Additional alloy info: Alloy designations commencing with the number 1, containing not less than 99% aluminum by weight.... Which are considered alloys in the trade and referred to as alloys in the scope... are actually not classifiable as alloys for tariff purposes but are alloys for scope purposes.**



# Definitely within Scope

- **Profiles (always extruded) Heading 7604**
- **Pipes and tubes (if extruded) Heading 7608**
- **Rod and bars (if extruded) Heading 7604**
- **Incomplete products or parts of unfinished products (if extruded)**
- **Unfinished heat sinks**
- **Carpet trim, door thresholds, electrical conduits, fence posts**
- **Above provided made of a qualifying alloy**



# QUALIFIERS TO BE WITHIN SCOPE

- **Composed of one of the included aluminum alloys in the case (commencing with 1, 3 or 6).**
- **Manufactured by extrusion method.**
- **Not a finished product i.e. not complete**
- **Not a kit within meaning of the scope, e.g. aluminum shower door kits without the glass**
- **Goods identified by reference to their end use as carpet trim, heat sink, etc.**



# Definitely outside of Scope

- **Finished products**
- **Finished heat sinks as defined in the scope**
- **Complete kits**
- **Products not extruded**
- **Products not made of a qualifying alloy**



# SHAPES AND FORMS

## Examples of Standard Shapes –

- **Angles, Channels, I-Beams and H-Beams**
- **Round, Square and Rectangular Tube, Rod and Bar**
- **Flat Bar and T-Bar**
- **Schedule Pipe**
- **Handrails**
- **Hex Solids**
- **Fence shapes**
- **Mullions and Gutters**



# Extrusion Images -- Profiles

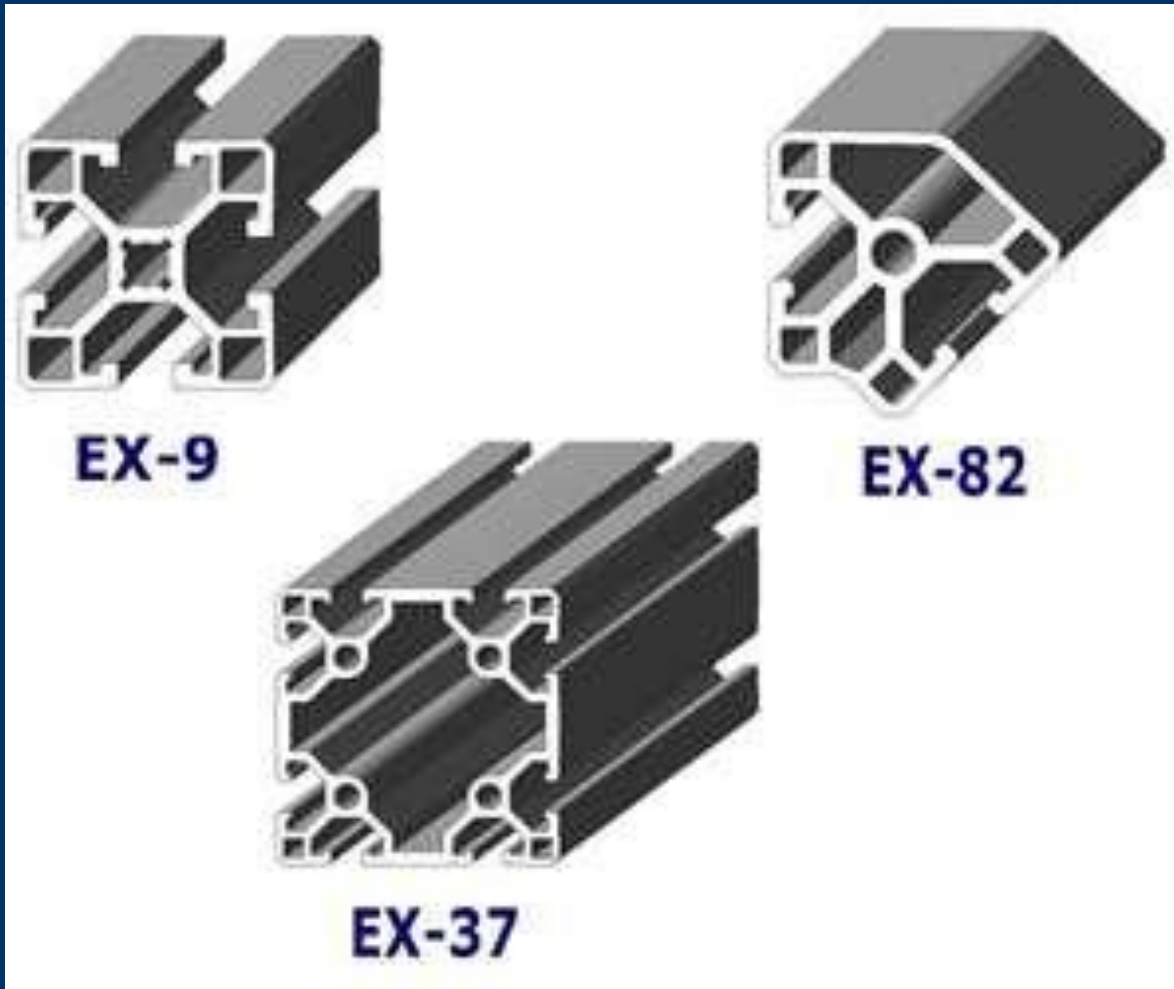



# SHAPES AND FORMS

**Some Standard Shapes:**

**Gutter Beams**

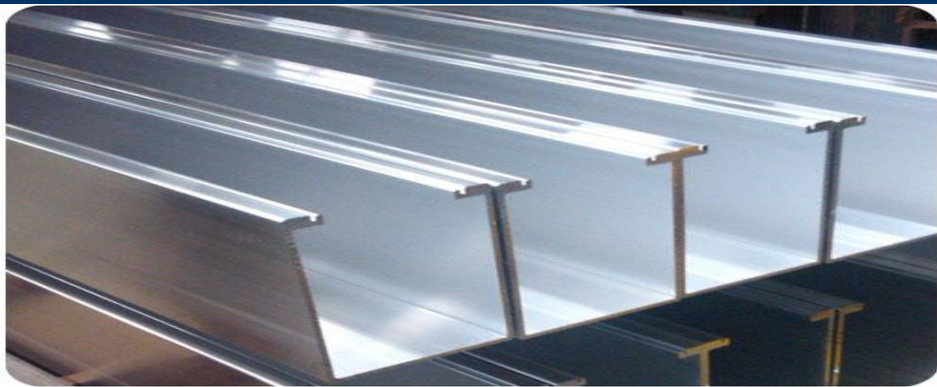

**Storefront Mullions**

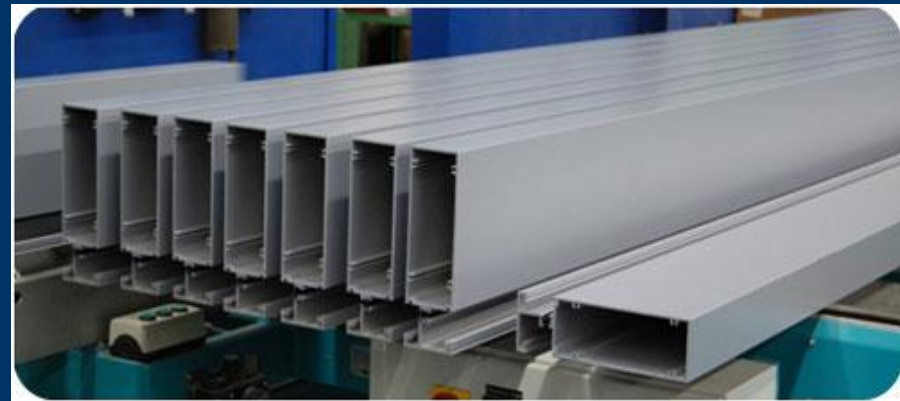

# SHAPES AND FORMS

## More Standard Shapes:

### Bar and Rod



### Angle and Channel



### Pipe and Tube



# SHAPES AND FORMS

Custom Shapes: The Possibilities Are Truly Endless

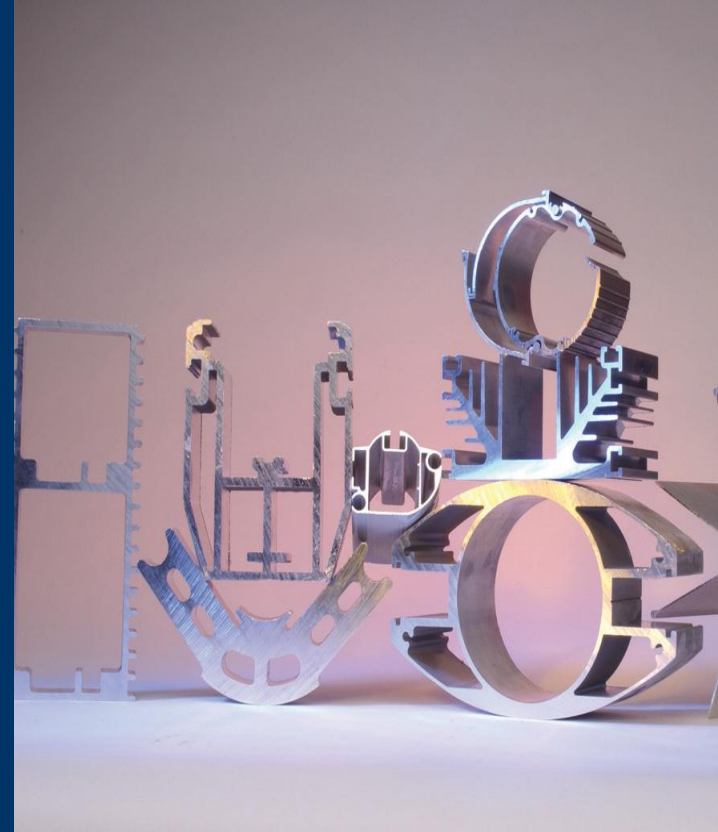
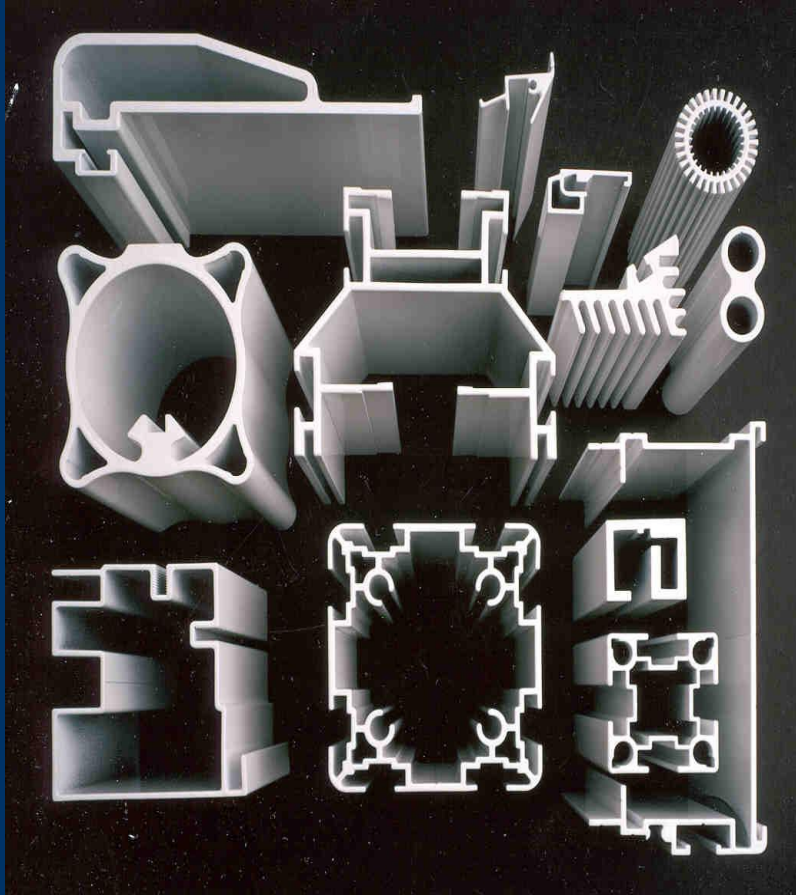

U.S. Customs and  
Border Protection

# SHAPES AND FORMS

- **Scope: “Aluminum extrusions that are drawn subsequent to extrusion (“drawn aluminum”) are also included in the scope.”**
- **Drawn aluminum is not easily distinguishable from other extruded aluminum tubular products.**



# SHAPES AND FORMS

The scope is not limited by size; small and miniature extrusions are covered.



# FINISHING

- **Scope: “Aluminum extrusions are produced and imported with a variety of finishes (both coatings and surface treatments). The types of coatings and treatments applied to subject aluminum extrusions include, but are not limited to, extrusions that are mill finished (*i.e.*, without any coating or further finishing), brushed, buffed, polished, anodized (including bright-dip anodized), liquid painted, or powder coated.”**





# FINISHING

Anodizing is most common in clear, bronze, black, gold, silver, and nickel; however, other colors are available.

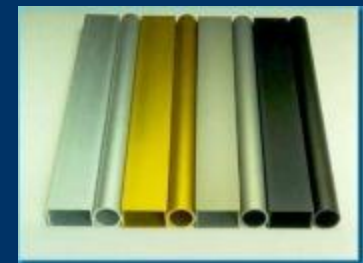
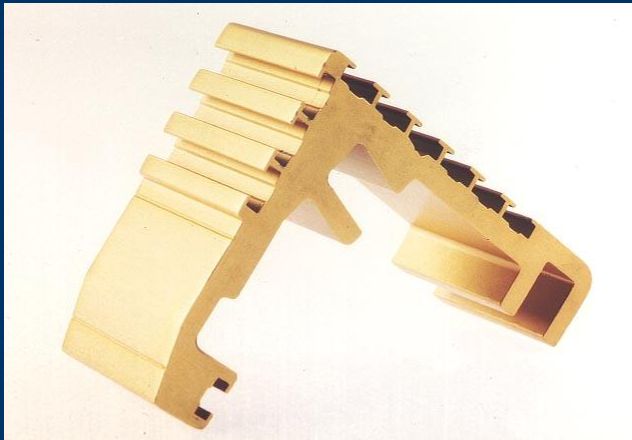

# FABRICATION

- **Scope:** “Aluminum extrusions may also be fabricated, i.e., prepared for assembly. Such operations would include, but are not limited to, extrusions that are cut-to-length, machined, drilled, punched, notched, bent, stretched, knurled, swedged, mitered, chamfered, threaded, and spun.”





# FABRICATION

## Examples of Fabrication Processes --

- Precision Cutting-to-Length
- Mitering
- Punching / Drilling
- CNC Machining
- Tapping
- Skim Cutting
- Counterboring / Countersinking
- Notching, Bending and Deburring
- Assembly



# FABRICATION

## Examples of CNC Machined Aluminum Extrusions

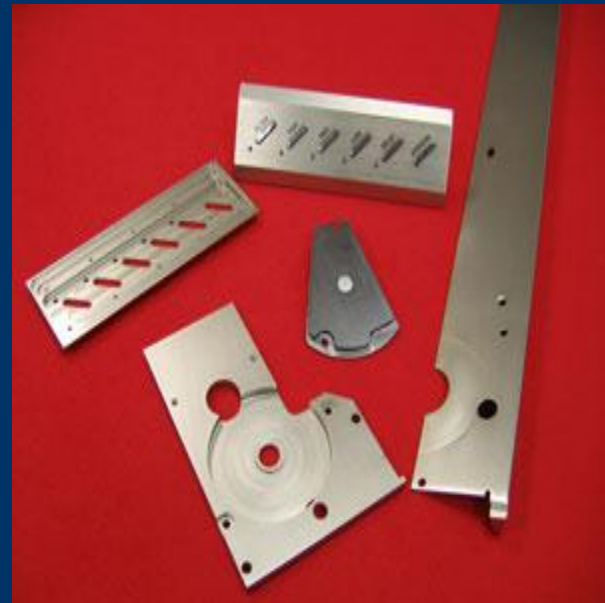

# FABRICATION

## Examples of Punched And Notched Aluminum Extrusions

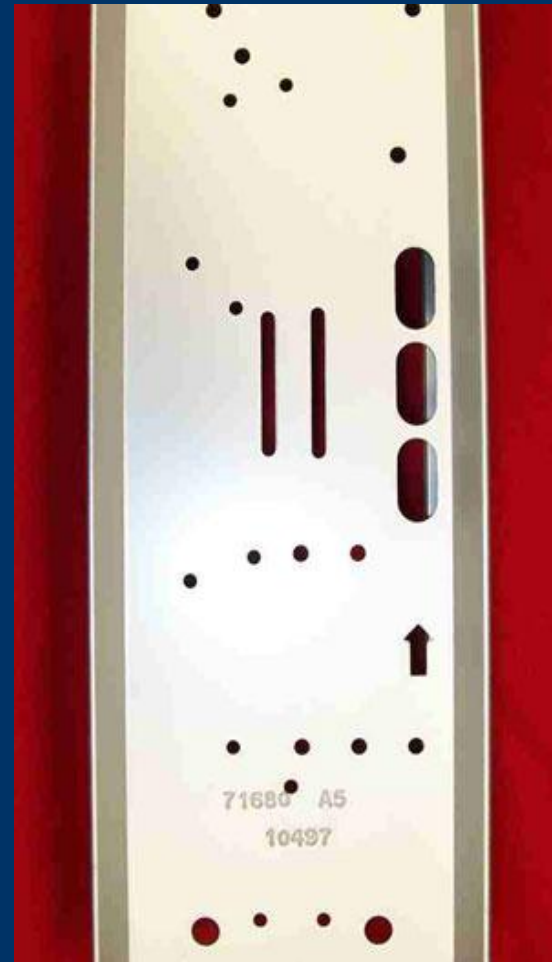

# FABRICATION

## Examples of Bent and Formed Aluminum Extrusions

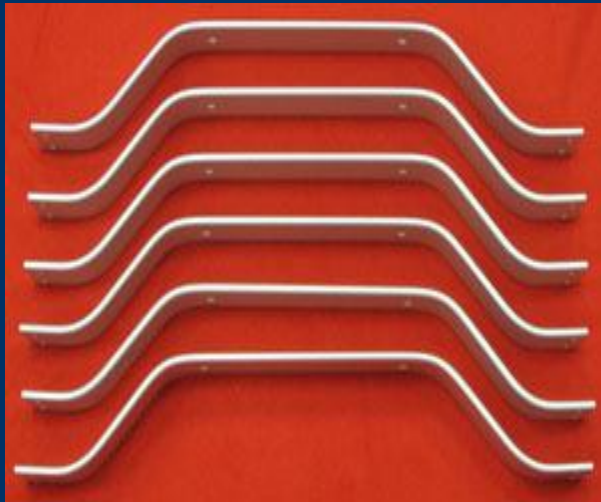

# SUBASSEMBLIES

## Scope:

- **“The scope includes the aluminum extrusion components that are attached (e.g., by welding or fasteners) to form subassemblies, i.e., partially assembled merchandise unless imported as part of the finished goods ‘kit’ defined further below.”**

**“A finished goods kit is understood to mean a packaged combination of parts that contains, at the time of importation, all of the necessary parts to fully assemble a final finished good and requires no further finishing or fabrication, such as cutting or punching, and is assembled ‘as is’ into a finished product.**



# SUBASSEMBLIES

Examples of subassemblies containing aluminum extrusions



# PARTS AND FINAL GOODS

## Scope:

- **“Subject aluminum extrusions may be described at the time of importation as parts for final finished products that are assembled after importation, including, but not limited to, window frames, door frames, solar panels, curtain walls, or furniture. Such parts that otherwise meet the definition of aluminum extrusions are included in the scope.”**

**“Subject extrusions may be identified with reference to their end use, such as fence posts, electrical conduits, door thresholds, carpet trim, or heat sinks (that do not meet the finished heat sink exclusionary language). Such goods are subject merchandise if they otherwise meet the scope definition, regardless of whether they are finished products and ready for use at the time of importation.”**





# PARTS ASSEMBLED AFTER IMPORTATION

**Most aluminum  
extrusions are  
parts for other  
goods, as in the  
case of this  
commercial door  
“crash bar”:**





# EXTRUSIONS IMPORTED READY FOR USE

- Some aluminum extrusions are imported ready for use (e.g., as final goods themselves).
- The term “kit” may not be applied to such goods merely by inclusion of fasteners in the packaging.
- Examples:

carpet trim



electrical conduit



door thresholds



# EXTRUSIONS IDENTIFIED BY END USE

- Heat sinks are also identified with reference to their end use (dissipation of heat)
- Heat sinks serve a wide variety of applications and come in many different sizes and shapes:

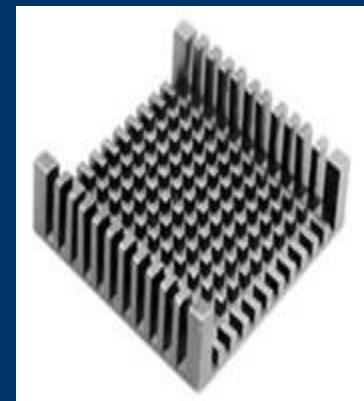
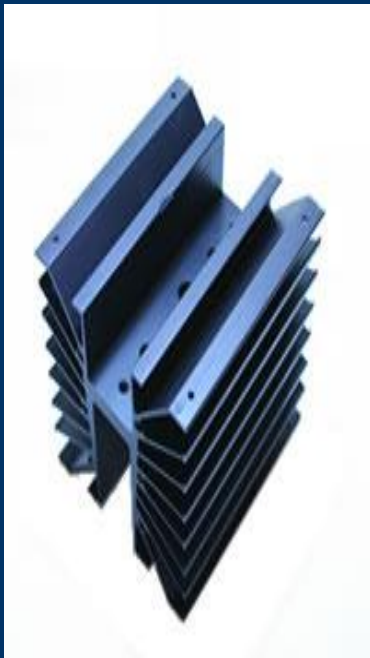

# WHICH HEAT SINKS ARE SUBJECT TO THE AD/CVD ORDER?

The Scope *includes* heat sink blanks and fabricated heat sinks from China:

- Heat sink blanks: full length extrusions used to produce heat sinks.
- Fabricated heat sinks: produced from a heat sink blank that has been cut-to-length, precision machined, and/or otherwise fabricated to the end product specifications; not yet tested or assembled onto other materials.



# NOT SUBJECT: FINISHED HEAT SINKS

The scope *excludes* finished heat sinks:

- Finished heat sinks differ from fabricated heat sinks in that they have been fully, albeit not necessarily individually, tested and assured to comply with the required thermal performance end-use specifications.
- Finished heat sinks are sold to electronics manufacturers.
- The design and production of which are organized around meeting certain specified thermal performance requirements.



# Sanitary Ware

- Subheading 7615.20 provides for sanitary ware and parts thereof, of aluminum.
- Aluminum extrusions may be incorporated into various products classified in this subheading.



# Sanitary Ware

- Examples of sanitary ware that may incorporate aluminum extrusions:
  - Cup holder
  - Toilet paper holder
  - Toothbrush holder

\*Scope includes parts; excludes finished goods



# Sanitary Ware

- Further Examples:
  - Soap dish
  - Sponge basket
  - Countertop bath caddy

\*See EN 73.24 for more examples



# Heading 8302

- Heading 8302 provides for base metal mountings, fittings and similar articles suitable for furniture, doors, staircases, windows, blinds, coachwork, saddlery, trunks, chests or the like; base metal hat racks, hat-pegs, brackets and similar fixtures; castors with mountings of base metal; automatic door closers of base metal; and base metal parts thereof.
- Various products classified in heading 8302 may incorporate extruded aluminum components.





# Examples of articles classified in Heading 8302 that may be included in scope:

- Hinges and parts (8302.10)
- Casters and parts (8302.20)
- Latches for windows and doors (8302.41), for furniture (8302.42), etc.

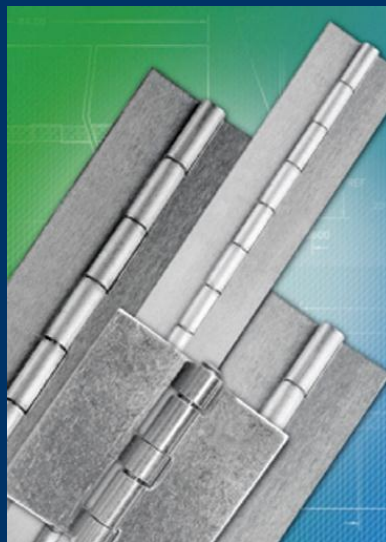

## Examples of articles classified in Heading 8302 that may be included in scope:

- Window shade head rail with Velcro (8302.41)
- Handles for doors (8302.41)
- Handles for furniture (8302.42)



# Examples of articles classified in Heading 8302 that may be included in scope:

- Drawer slides (8302.42)
- Mounting brackets for motor vehicles (8302.30), buildings (8302.41), furniture (8302.42), etc.

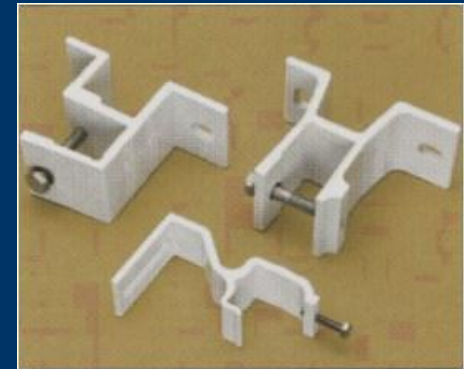
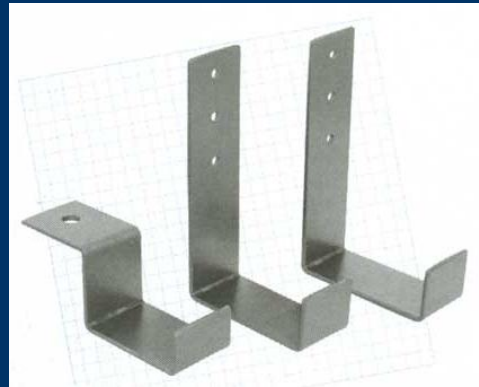
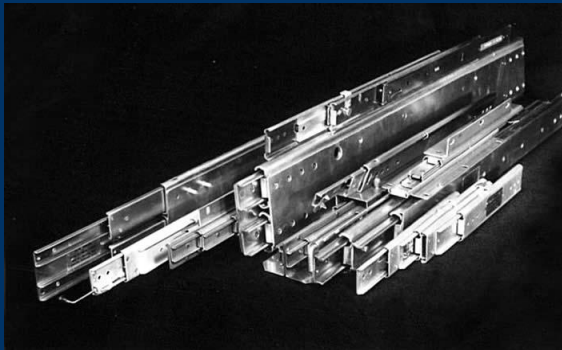

# Aluminum Extrusions

- N128477
  - Aluminum continuous door hinge (also called a piano hinge)
  - Produced by extrusion process
  - Aluminum Association Series Designation number 6063
  - Classified in subheading 8302.10.60
  - May be included in scope



# Aluminum Extrusions

- Part of a TV wall mount
  - Made of extruded aluminum
  - Classified in subheading 8302.50, which provides for base metal hat-racks, hat pegs, brackets and similar fixtures, and parts thereof.
  - May be included in scope if made of aluminum alloy commencing with numbers 1, 3, or 6.



# Aluminum Extrusions

- N224295
  - Aluminum rail used to mount a strip door
  - Produced by extrusion process
  - Classified in subheading 8302.41.60
  - May be included in scope



# Final Scope Ruling (2/3/12) on Drapery Rail Kits

- Aluminum rail is produced by extrusion process; brackets and finials are made of steel
- Classified in 8302.41.60 (N192095)
- DOC determined this is not a “Finished Goods Kit” because it is imported without the necessary drapes/curtains
- Included in the scope





# Final Scope Ruling on Drapery Rail Kits (cont.):

- DOC determined that the drapery rails are comparable to the products examined in the Awnings Scope Ruling, in which the textile covers were purchased separately and not included with the awning mechanism at the time of importation.
- Consistent with the Awnings Scope Ruling, DOC found that an assembled drapery rail kit absent the integral drape or curtain does not function as a finished good.





# 8306.30

## Photograph, picture or similar frames... and parts thereof

- Finished goods containing aluminum extrusions as parts that are fully and permanently assembled and completed at the time of entry are **excluded** from the scope.
  - Example: Picture frame with glass pane and backing material
- Parts for final finished products that are assembled after importation are **included** in the scope.
  - Example: Parts of picture frames imported without backing or glass



# Subheading 7616.99

- covers other articles of aluminum
  - not more specifically provided for in any other heading of the tariff
- other aluminum articles made from extrusions, if of a qualifying alloy, are within the scope

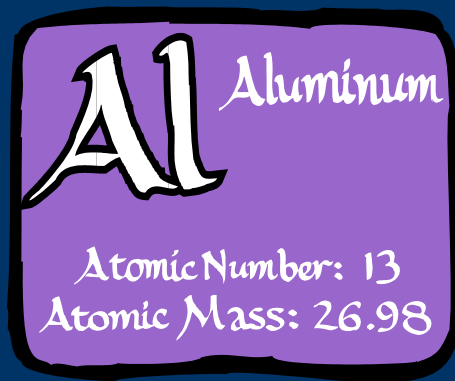

# Aluminum Frames

## New York Ruling N186281



- made from aluminum extrusion strips cut to length
- after importation, fabric stretched across the opening of the frame
- multiple applications, for example, used to cover ventilation fan openings in a barn
- if made of a qualifying alloy, appear to be within the scope



# Aluminum Frames for Solar Panels

## New York Ruling N139353

- made from extruded aluminum cut to length
- no further processing after importation except to assemble, aluminum extrusion strips are just snapped together
- specifically named in the scope of the order and covered by the scope if made of a qualifying alloy



# Predrilled Aluminum Poles (Parts) for Pool Cleaning – HQ H171296



- made of series #6063-T832
- imported as parts for pool cleaning, used for connecting cleaning attachments such as brushes, frames and vacuum handles
- similar to the Rubbermaid Cleaning System scope ruling issued by Department of Commerce and would be within the scope



# Seats – Heading 9401, HTSUS

- Subheadings 9401.10, 9401.20, 9401.30, 9401.71 and 9401.79

## Seats of a kind used for aircraft

- 9401.10

## Seats of a kind used for motor vehicles

- 9401.20

## Swivel seats with variable height adjustments

- 9401.30

## Other seats with metal frames

- 9401.71 Upholstered
- 9401.79 Other

- Subheadings 9401.90  
Parts (of seats)



# Seats – Heading 9403, HTSUS

- **Subheadings 9403.10, 9403.20**
  - Metal furniture of a kind used in offices**
    - **9403.10**
  
    - Other metal furniture**
      - **9403.20**
  
- **Subheadings 9403.90**
  - Parts (of other furniture)**



# New York Ruling – N179797 (11/08/2011)

- **Kingfish Folding Deck Chair**
  - Aluminum frame
- Not subject to AD/CVD duties when imported finished.
- Frame w/out upholstered seat, back & arm pads AD/CVD applicable.





# New York Ruling – N097755 (03/23/2010)

- **Torsby Underframe**
  - Steel frame (tabletops are interchangeable, and marketed and sold separately)
- If frame was of extruded aluminum classify GRI 2 (a) complete article.
- Does not have all parts necessary for final finished good for purposes of the scope. Appears to qualify for AD/CVD.
- See scope ruling for Rubbermaid on cleaning system components.



# New York Ruling – N144436 (02/06/2011)

- **Aluminum frame medical cart**
  - **Frame T-6 grade aluminum**
  - **Composed of extruded profiles**
  
- **Subject to AD/CVD duties as the medical cart is unfinished requiring further manufacture and assembly.**

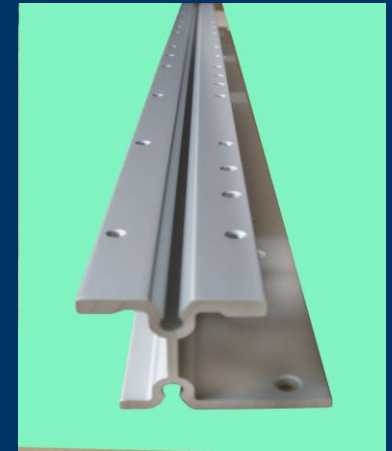

# Aluminum Extrusions

## Heading 9506

- Aluminum extrusions are incorporated into a wide array of products that are classified in Heading 9506.
- Heading 9506 covers articles and equipment for general physical exercise, gymnastics or athletics, as well as requisites for other sports and outdoor games.
- While completed kits / finished goods are excluded from the scope, the following items imported as either parts or in an unfinished condition are most likely included within the scope of the order. Such items include...



# Parts of Heading 9506 Made from Aluminum Extrusions



- **Playground Equipment**
  - Arches of platforms, crossbars, climbers, ladders, swing supports, steps, bridges

- **Swimming Pools**
  - Panels, posts



# Parts of Heading 9506 Made from Aluminum Extrusions



- Exercise and fitness equipment
  - Extruded aluminum beams as notated above



# Parts of Heading 9506 Made from Aluminum Extrusions

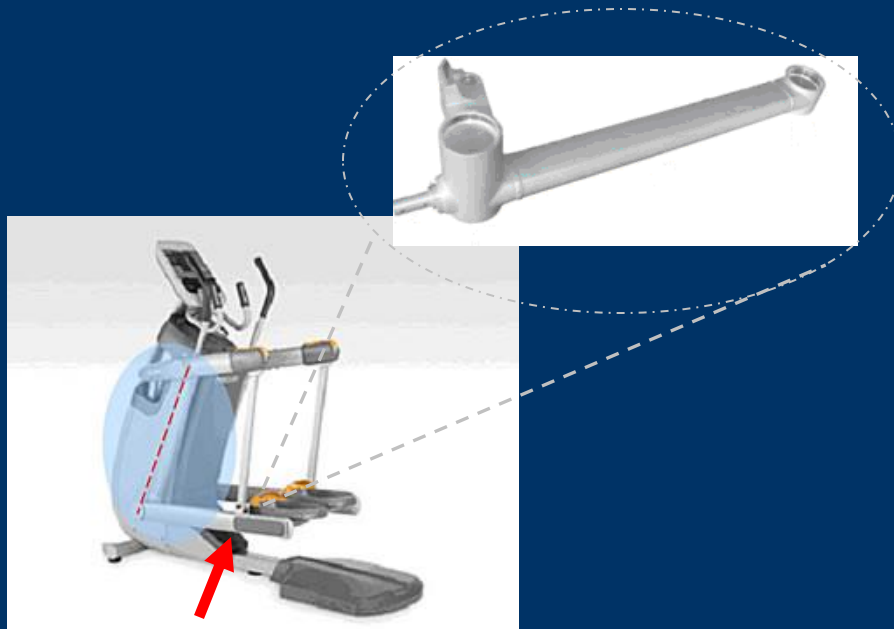

- Exercise and fitness equipment
  - Beams and brackets

- In-line Speed Skates
  - Wheel frames



# Unfinished Goods of Heading 9506 Made from Aluminum Extrusions



- Baseball bats without grip or end cap



- Tennis racquet frames without handle or string



- Lacrosse sticks without head



# Conclusion

- **Ongoing process because of complexity and breadth of this case.**
- **Very pleased to have had the expertise of the DOC to assist in this project.**
- **It is expected that future scope rulings from the Department of Commerce will continue to define these cases.**

